



# Super Duty Proteous 1000

Installation Manual



*Installation flowchart on page 6*



## Installation

### Page 1

Preliminary Checks  
Important Safety Information  
Motor Specifications

### Page 2

Installation Layout and Cable Structuring

### Page 3

Motor and Baseplate Dimensions  
Emergency Clutch Override

### Page 4

Installation using Concrete Base Plate

### Page 5

Magnet Placement

### Page 6

Successful Setup Flowchart

### Page 7

Control Board Overview and LCD Interface

### Page 8

Internal and External Transformer  
Low Voltage Cable Extension

### Page 9

Battery Backup For Powered Systems

### Page 10

Solar System Installation

### Page 11

Solar System Installation cont.

### Page 12

[Energy Saving Mode for Solar Systems](#)

### Page 13

Setting the OPENING Direction  
Automatic Setup Cycle (Limit Learning)

### Page 14

Wireless Equipment Pairing & Deleting

### Page 15

Using your Remote's  
Antenna Connections

### Page 16

Wireless Button Configuration  
Wireless Keypad Configuration

### Page 17

Wired Button Connection

### Page 18

Wired Keypad Connection and Configuration

### Page 19

GSM Receiver Connection  
Wi-Fi Switch Connection  
Intercom Connection

### Page 20

Photocell and Retro Reflective Sensor Connection

### Page 21

Configuring the Photocell Logic [Check Before Motion](#)

### Page 22

Automatic Close Settings

### Page 23

Safety Lamp and Configuration

### Page 24

Induction Loop Connection

## ADVANCED Adjustments

### Page 25

Configuration of System START inputs (Loops & Timers)

### Page 26

Safety Lamp Pre-Flashing Times

### Page 27

Sensitivity and Power Settings

### Page 28

Ramp Feature and Slowdown Adjustment

### Page 29

Auxiliary Light/Driveway Light Connection and Setting

### Page 30

Pedestrian Settings and Logic

### Page 31

Start and Stop Input Configuration

### Page 32

Safety Edge Logic [Check Before Motion](#)

### Page 33

System Overrides (Manual Control)  
Reset to Factory Default

### Page 34

Service and Cycle Counters

### Page 35

Bi Parting Gate (Syncro)

## Other

### Page 36

Troubleshooting

### Page 37

Compatible Accessories  
Warranty Terms

## Preliminary Checks

To ensure safety and an efficient automation make sure the following requirements are met:

1. The gate structure must be suitable for automation.
2. Make sure that the gate move properly and uniformly without any irregular friction during their entire travel.
3. The gates wheels and track must be in good condition with no biting, no rust and must be well greased.
4. The gates should be able to be freely opened and closed before installing the gates automation system.
5. It is strongly suggested to have a gate stop installed for the open position for setup and emergency purposes.

## Important Safety Information

Installer and owners should observe the following:

1. Make sure that there is sufficient space for the gate to slide open fully without interference.
2. The solar box must be installed in the area within 10 meters maximum cable distance from motor.
3. Do not change with parts or components not supplied by the manufacturer, this includes sensors, buttons, solar panels, transformers and any component not listed in the compatibility list.
4. Make sure all wiring works are correct and in good condition before connecting the battery, solar panel or transformer to the control panel.
5. Turn off the power and disconnect the battery when doing any maintenance.
6. Ensure the control panel box is free from water leakage to avoid short circuiting of the control panel.
7. Do not supply mains power directly to the motor, control box or any accessories.
8. Do not install the operating system if in doubt. Contact the manufacturer.
9. Do not cross the gate while it is operating, Safety sensors are only to prevent accidents or injuries.
10. Keep the remote controls in safe place and away from children.

Before beginning installation the manual should be read thoroughly concerning all aspects of the installation including all precautions and safety information.

Proper steps should be taken to ensure efficient and safe installation for vehicles, property and persons within the operators working radius.

The system is fitted with an over current sensing feature to assist in preventing damages, injuries and death. All precautions must be taken by the installer that adjustments are set correct based on the gates weight, height and length. The system sensitivity should be set to allow consistent operation of the gates under normal operating conditions. This does not include operating against wind. The system may not detect against light loads such as small object, young children and animals. It is the operators duty to ensure that the area is clear prior to operation. Photo sensors or Reflective sensors should always be installed to assist in accident or death prevention. Rubber edging should be installed onto the gates to assist in dampening any accidents or damages.

You agree to install this product following any and all safety requirements listed in this manual or required under local, state or national regulations. APC Automation Systems, its distributors, stockist or sellers are not liable for any direct, indirect, incidental, special or consequential damages or loss of profit wether based in contract or any other legal theory during the course of warranty or afterwards. If you do not feel capable of properly installing the operator based on the above information or otherwise do not proceed.

## Motor Specifications

Gate Max. Weight	1000KG
Motor Power	550W
Max. Speed	26 cm/s
Max. Thrust	900N
Duty Cycle	60%
Operating Temperature	-20°C - + 55°C
Protection	Ip44
Max. Accessories Load	7W
Protection fuses	T.16A

# Installation Layout

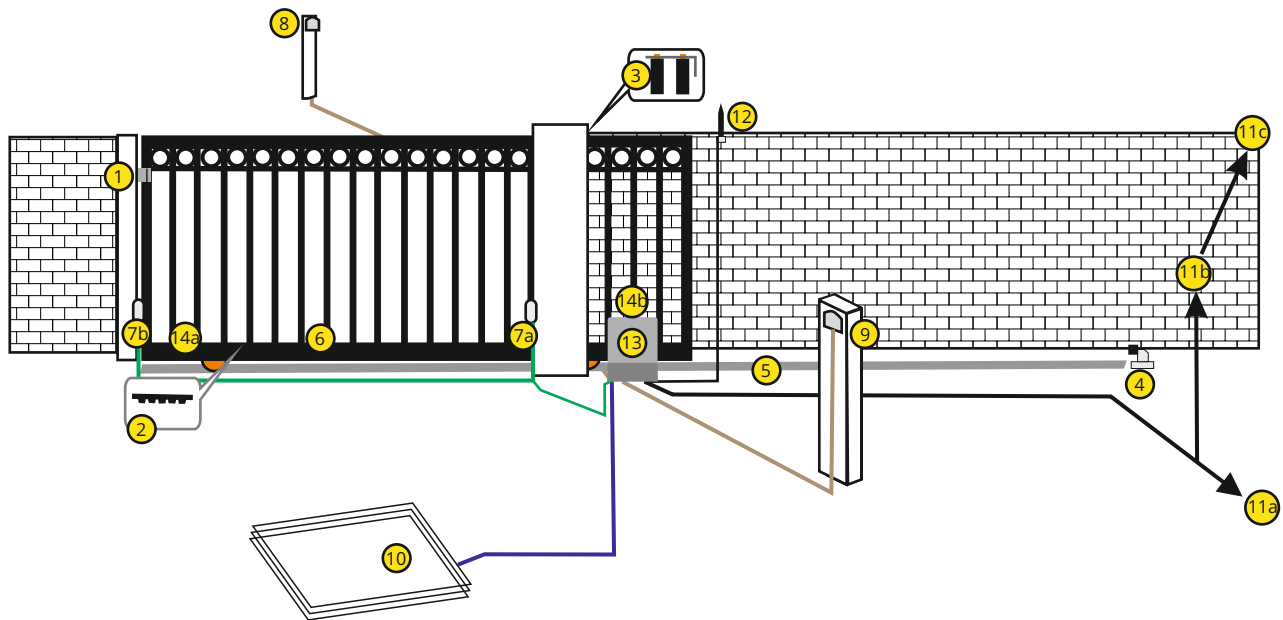
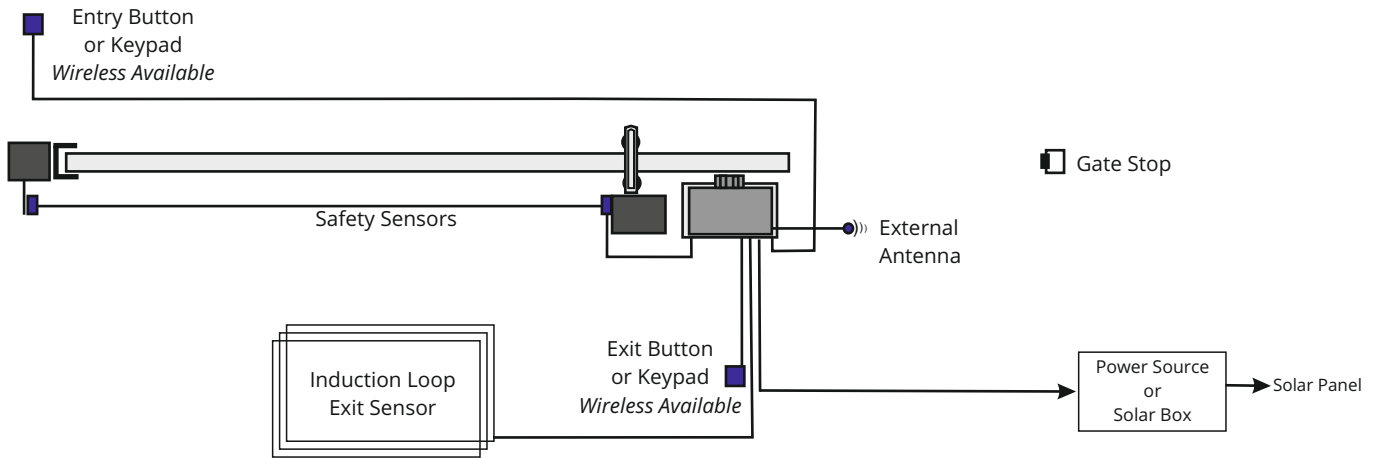

## Requiring Wiring:

- Keypad - 4 Core (Wireless available)
- PBD-K - 4 Core (Wireless available)
- PBS-K - 2 Core (Wireless available)
- PE Sensor
  - Receiver - 4 Core
  - Transmitter - 2 Core
- Induction Loop 1 Core Teflon Cable

- 1 U Guide/Keep
- 2 Wheels
- 3 Rollers and Bracket
- 4 Gate Stop
- 5 Floor Track
- 6 Gear Rack
- 7a PE Sensor Transmitter
- 7b PE Sensor Receiver (Not required for Retro Reflective Sensor)
- 8 Entry Keypad/Push Button
- 9 Exit Keypad/Push Button
- 10 Induction Loop Exit Sensor
- 11a Power Source (Mains/Low Voltage)
- 11b Solar Box
- 11c Solar Panel
- 12 External Antenna
- 13 Gate Motor
- 14a Open Magnet
- 14b Close Magnet

## Motor And Base Plate Dimensions

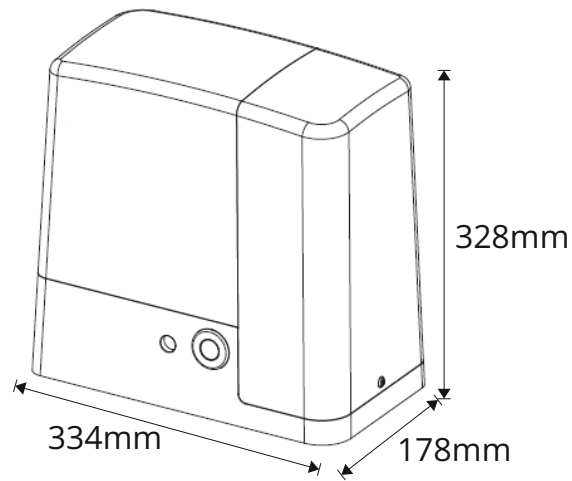

## Concrete in Base Plate

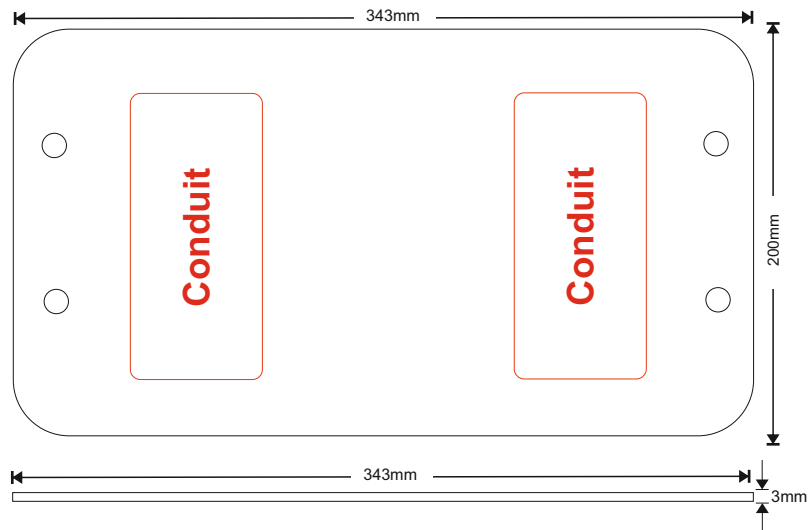

## Emergency Override/Clutch Override

### Unlocking

1. Operate the manual release moving back the key hole cover (J).
2. Insert the key in the cylinder lock (K) and turn it of 90° clockwise direction.
3. Insert and turn the triangle key (L) clockwise continuously til it physically stops.

### Locking

1. Insert and turn the triangle key (L) anti-clockwise continuously til it physically stops.
2. Insert the key in the cylinder lock (K) and turn it of 90° anticlockwise direction
3. Slide the cover (J) back to the original position.

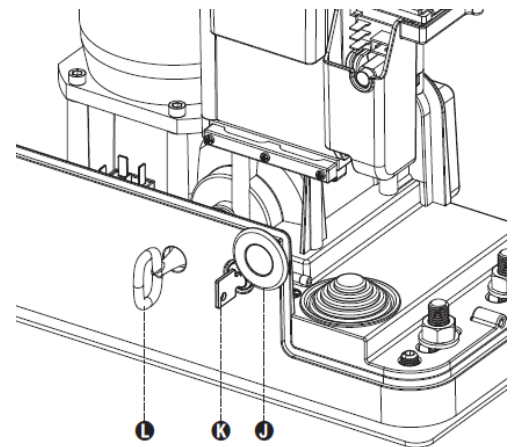

## Installation (Concrete in Base Plate)

1. Using the measurements indicated in the drawing of the concrete plate arrange for one or two conduits based on the accessories to be installed.
2. Assemble the two J bolts to the anchoring plate and fix them with the four nuts supplied. .
3. Pour the concrete and position the anchoring plate as per the drawing below.

1

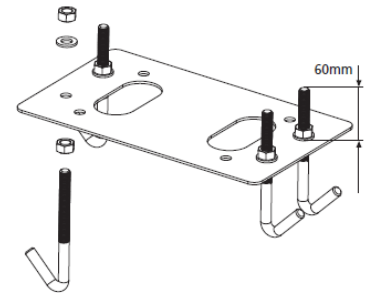
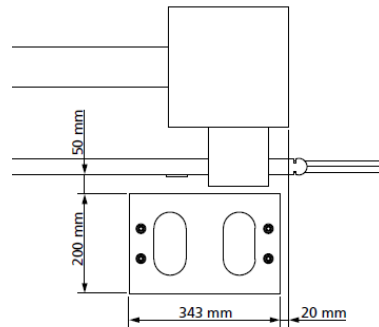
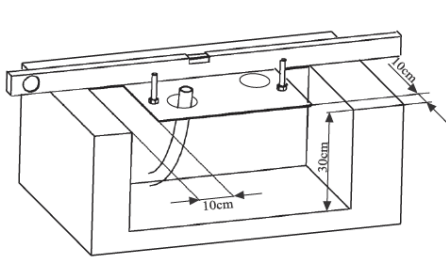

1. Wait for the complete setting of the concrete
2. Unscrew the two top nuts fixing the anchoring plate and put the motor on top of the anchoring plate noting measurement **A**. Ensure to thread the cables through plastic grommet **G**.
3. Insert the four threaded adjusters **C** with their nuts at each corner of the motor base and adjust to make the motor perfectly level.
4. Adjust so that the motor is perfectly parallel to the gate, then insert the two washers **R** and lightly screw the two fixing nuts **D**

2

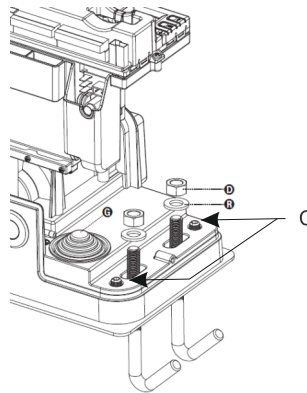
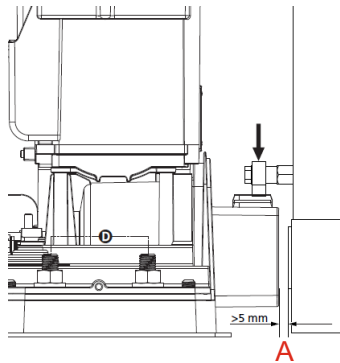

Install the gear rack onto the gate.

The best method for installation is to have the gate closed, sit the first piece on the pinion of the motor then fix directly to the gate in the center of the fixing hole (make sure it is 100% level first).

3

Now loosen the fixing and adjust the spacing between the motor's pinion and the gear rack (as illustrated) then re-tighten. Each piece of gear rack will clip into the previous piece and providing you use a level minimal adjustments will be required afterwards.

You can use the clutch feature of the motor to open and close the gate whilst the gear rack is fitted.

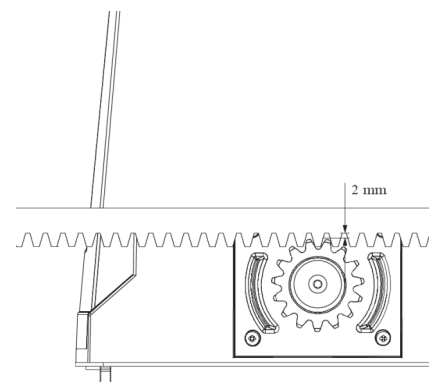

DO NOT SKIP THIS STEP

4

Test the gear rack installation by setting the motor to manual override then very slowly pull the gate open and closed, you will find tight and loose points in the gearing. These must now be rectified by loosening the fixing screws and adjusting the gear rack up/down until the gate is 100% consistent.

5

PROCEED WITH SX AND DX MAGNET PLACEMENT

## Sx and Dx Magnet Placment

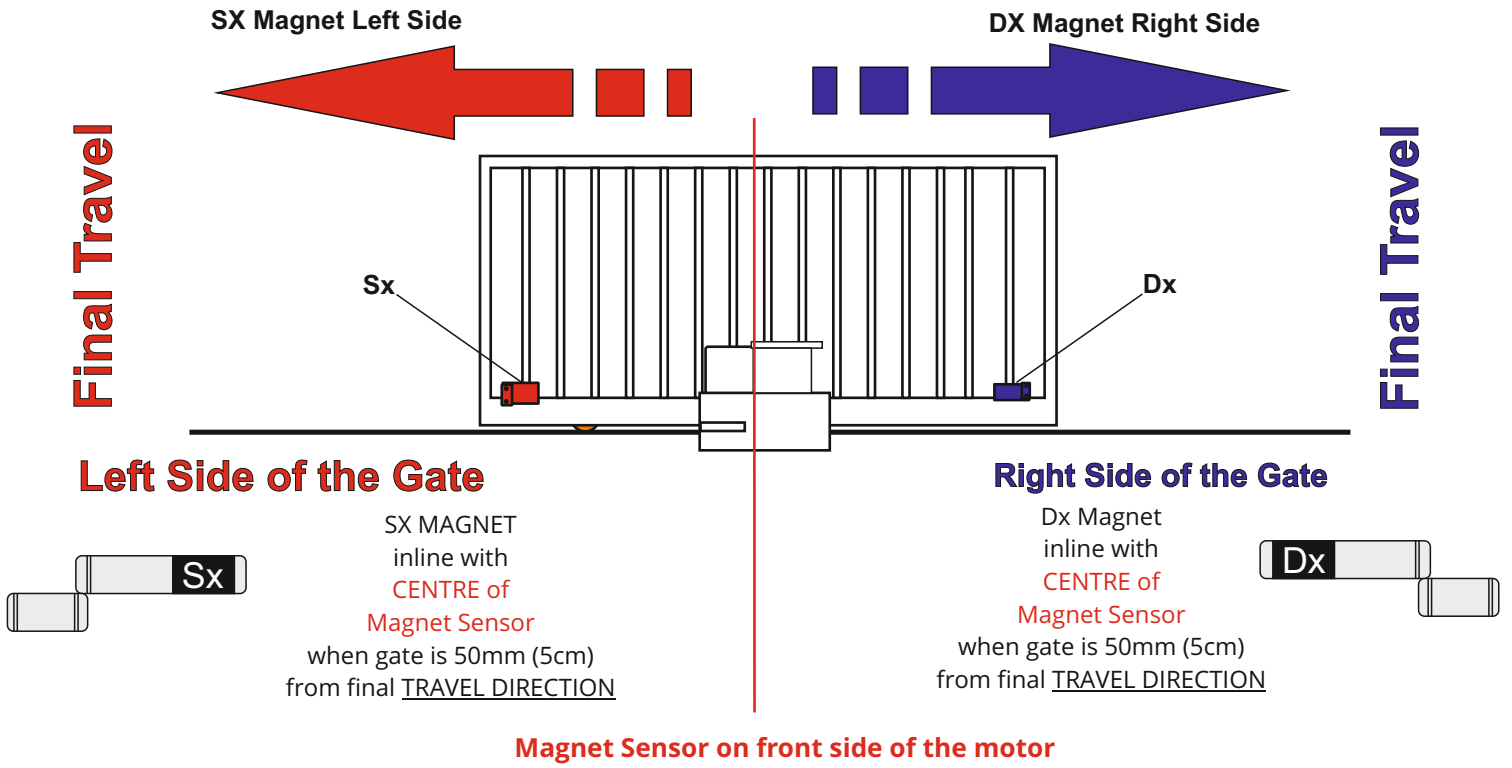

## Positioning Guidelines

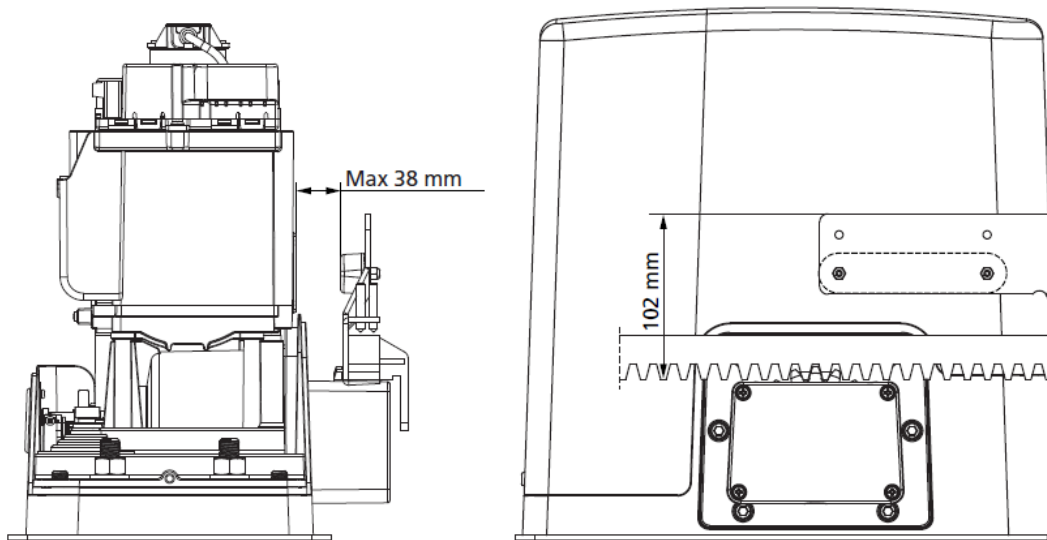

# Successful Installation flowchart

The below should be followed after following pages 3 through to 5 for the physical installation of the motor.

## Phase 1

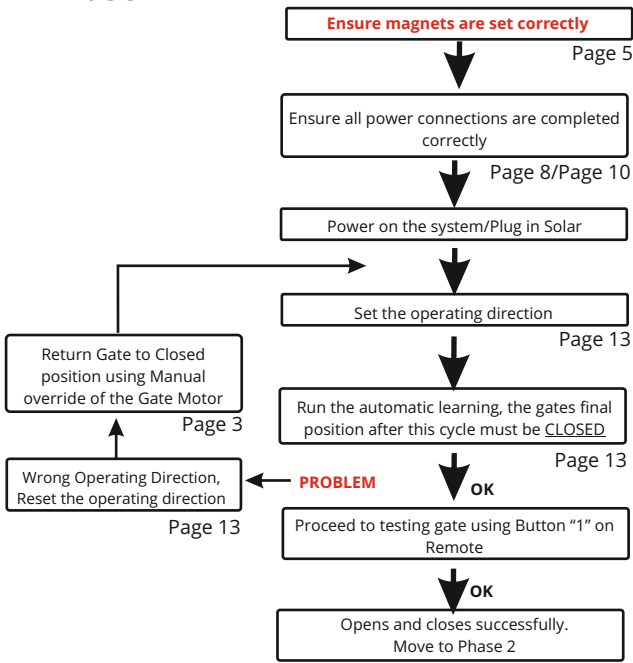

## Phase 2

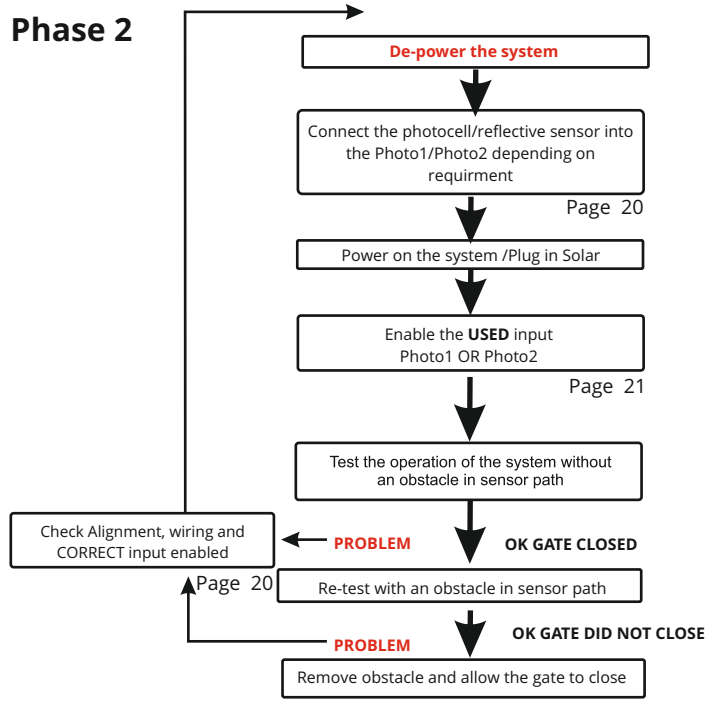

## Phase 3 (SOLAR ONLY)

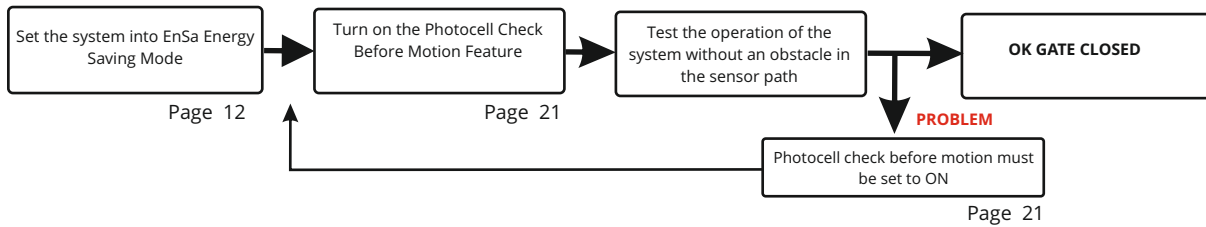



# Quick Reference Guide

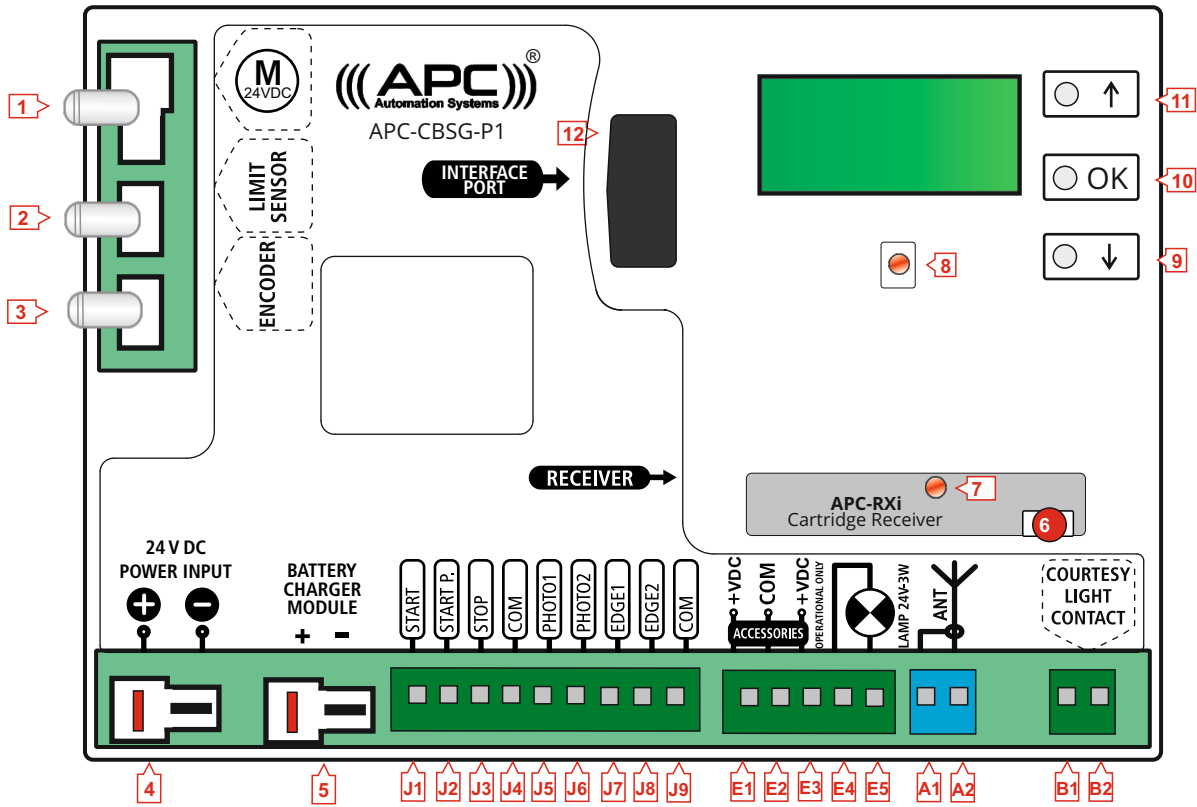

### Operational Inputs

- J1. Start (Full Operation) Command (N/O)
- J2. Start P. (Pedestrian Operation) Command (N/O)
- J3. Stop Command (N/C)
- J4. Common Ground

### Safety Inputs

- J5. Photocell Input 1 ((N/C)
- J6. Photocell Input 2 (N/C)
- J7. Safety Edge Input 1 (N/C)
- J8. Safety Edge Input 2 (N/C)
- J9. Common Ground

### Accessories Power

- E1. Constant +V DC Output (24V Solar / 34V on Power)
- E2. +V DC Output Only when in an operating cycle (24V Solar / 34V on Power)
- E3. Common

### Lamp Output 24V

- E4. Lamp Output + (24V DC Max 3W)
- E5. Lamp Output - (24V DC Max 3W)

### Antenna

- A1. Antenna Shield (applicable with external antenna)
- A2. Antenna Core

### Light Output

- B1. Pole 1
- B2. Pole 2

### Pre-Connected Fixed Wiring

- 1. Motor Connection
- 2. Limit Switches
- 3. Encoder

### Voltage Supply

- 4. DC Power Input jack (Solar Input)

- 5. **Backup Battery Charger Port** (powered systems only)

### Remote Cartridge Receiver

- 6. Remote Pairing Button
- 7. Remote Cartridge LED indicator

### Overload

- 8. Overload LED indicator

### Menu

- 9. Menu Down / Operate Pedestrian
- 10. OK
- 11. Menu Up / Operate Full Gate

# LCD Interface

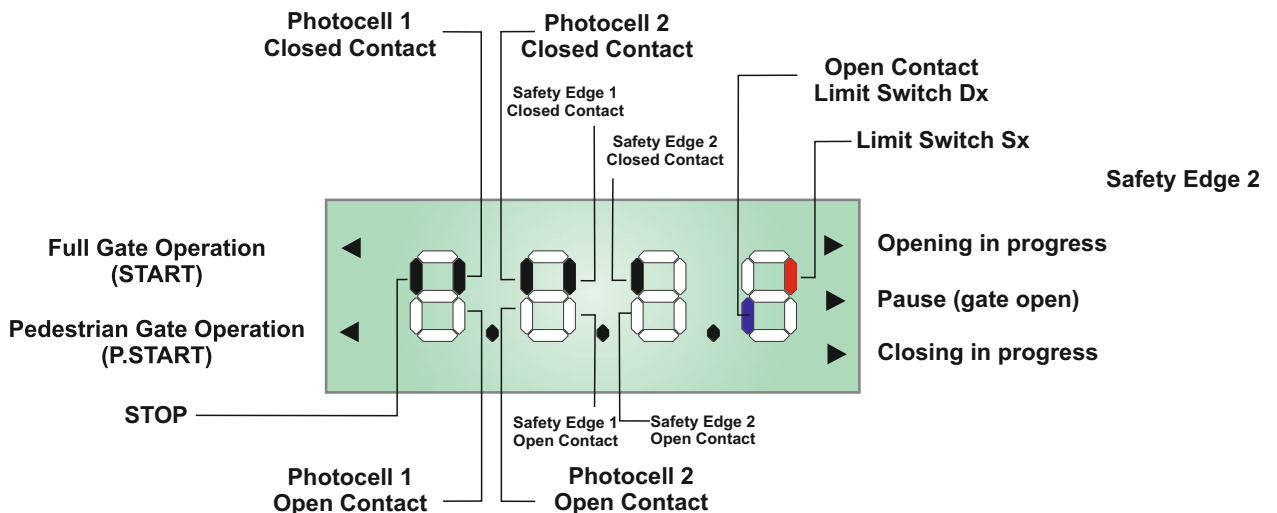

## Internal Transformer, wiring and Fuse

**HIGH VOLTAGE**

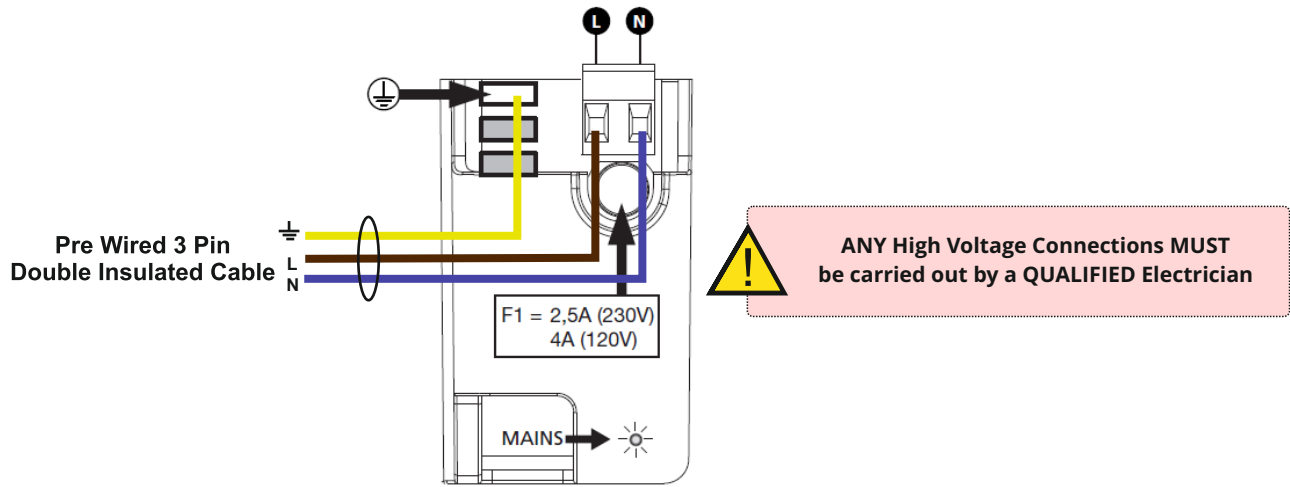

## APC External AC Transformer (Low Voltage Systems)



Ensure the transformer is **NOT** powered on before proceeding with any low voltage connections

The diagram below will illustrate the low voltage transformer connection to the bridge rectifier located UNDERNEATH the control board. The transformer should never be connected directly to the control board and must always be wired to the bridge, any other method of connection will result in immediate damage to the system.

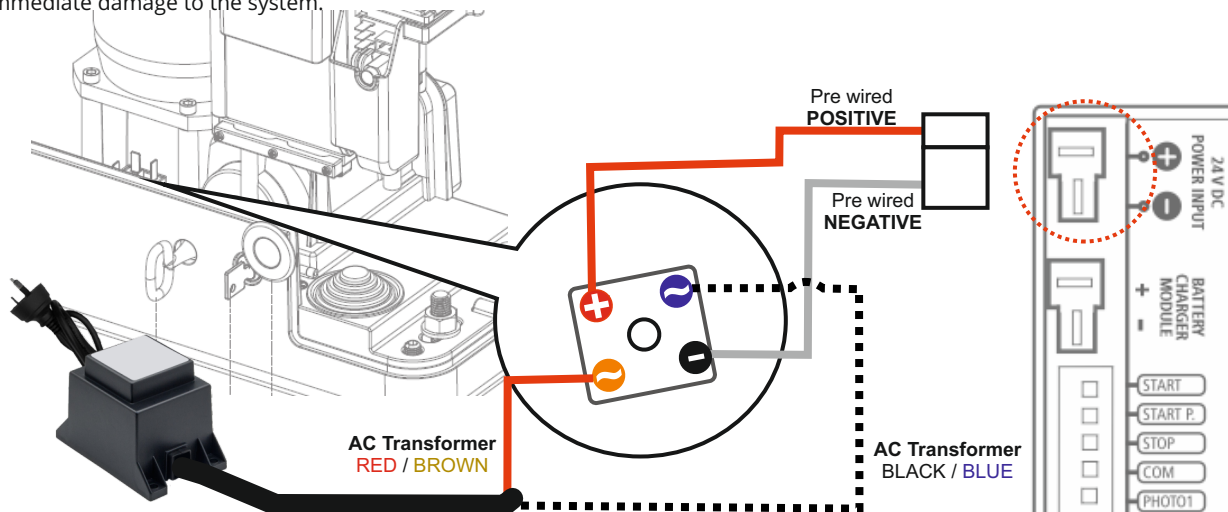

## Extending the APC External AC Transformer (low Voltage)



Ensure the transformer is **NOT** powered on before proceeding with any low voltage connections

Maximum cable distance: The low voltage transformer can be run up to 100m in cable distance when using a 2mm pair conductor or greater. To run the transformer to maximum capacity the cable must be cut at the LOW VOLTAGE SIDE within 10cm from the output.

**Note:** Use a weatherproof junction box to terminate the new cable to the transformer.

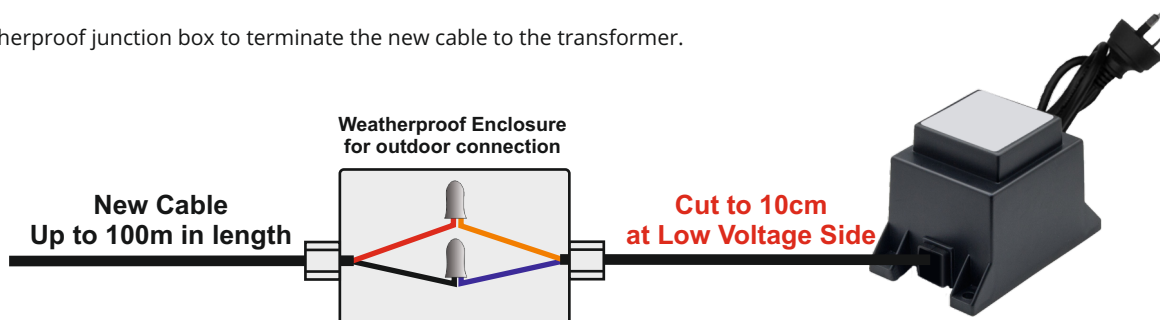

# APC Battery Backup (APC-P1-BATT)



Ensure the transformer is NOT powered on before proceeding with any low voltage connections

The diagram below will illustrate the internal battery connection input with the battery charger module. Ensure that the system is de-powered before beginning the wiring connection. Note: This system is only compatible with the APC-P5-BATT.

## 1. Connect batteries to battery system

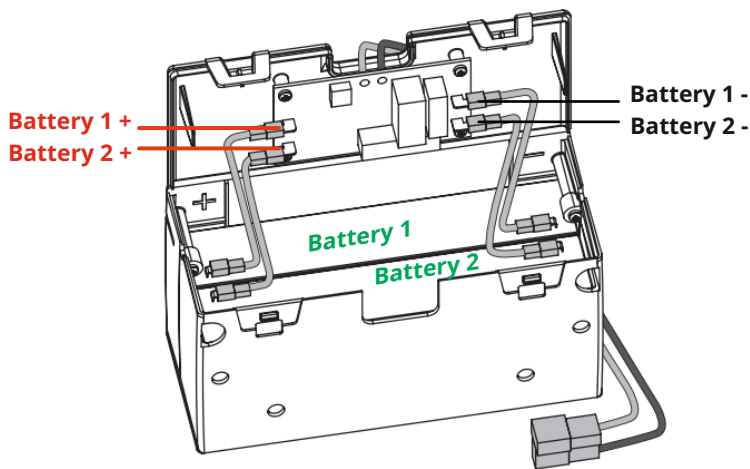

## 2. Fit into system and plug in

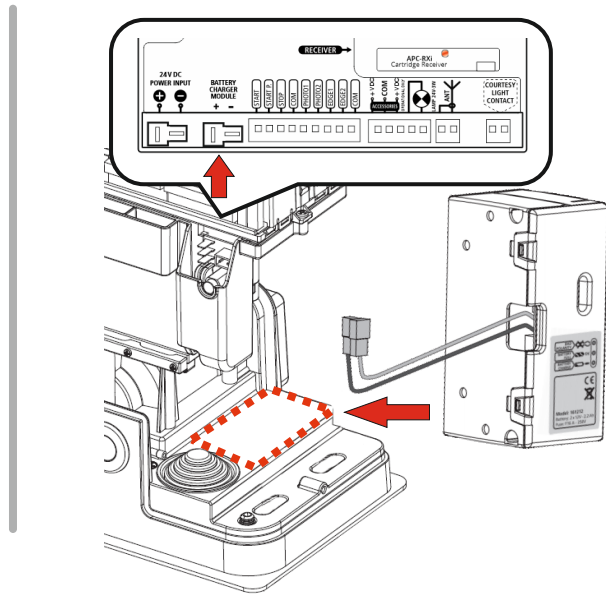

### INDICATIONS

The status of the battery pack is displayed by means of 3 LEDs:

- Yellow LED: batteries charging
- Green LED: batteries fully charged
- Red LED: at least one battery has been connected wrongly

In the case of a blackout, the battery charger automatically switches from recharge mode to back-up power supply mode (all LEDs are off); on restoration of mains power, the battery charger switches once more and the yellow LED comes on to indicate that battery charging is ongoing.



**PLEASE NOTE:** during battery charging, the cover of the battery charger can become hot; this is normal, and should not cause any concern.

### CHECKING FUNCTION AND TESTING

The following checks are performed immediately after having connected the battery to the control unit:

1. Check that the control unit is on (with mains power disconnected): the battery pack LEDs remain off.
2. Connect the automation device to the mains supply and check that the YELLOW LED is on, indicating that the battery is recharging correctly.
3. Disconnect the automation device from the mains supply; check that the YELLOW LED is off, then perform at least one automated device opening and closing manoeuvre, in order to verify that everything is operating perfectly, even in the case of battery operation.

**Please note:** depending on the type of automation device, movements might occur at reduced speed when the back-up battery is in operation.

4. On completion of the tests, reconnect the automation device to the mains supply.

## Solar System Installation

Taking into account that the solar panels maximum cable distance is 20 metres and the maximum distance between the solar box and the gate controller is 10 metres find a suitable location for the mounting of the box accordingly. Both the solar box and the solar panel are completely weatherproof and can be mounted in complete exposure to the elements.

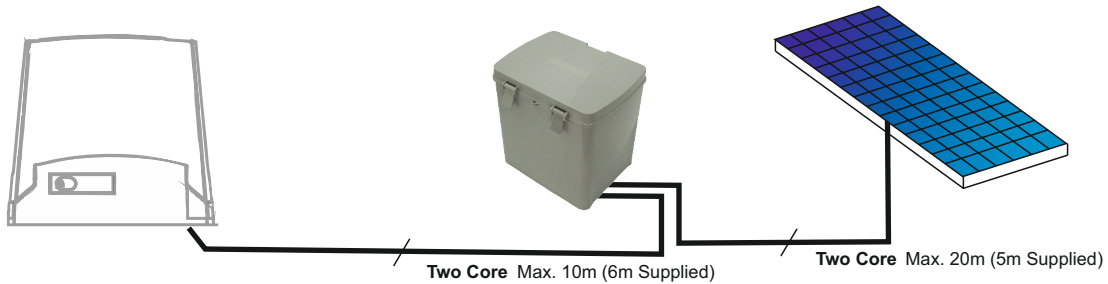

### Step 1: Installing the Solar Panel

LOOSLEY assemble the two clamps to the base plate.



Insert the post into the clamps and tighten. USE the rubber cutouts around the post for best grip



Assemble the base plate to the solar panel using the supplied bolts

1. The solar panel should be installed at 45° facing mid-day to afternoon sun.
2. Assemble and install the solar panel in a place that is exposed to the sun most of the day and as far as possible from any walls or trees.
3. Make sure that the two wires of the solar panel do not touch each other at any time during installation.
4. Install the solar panel at least 2m above the ground to protect it from dust and small stones.

### Solar Panel Placement

1. A solar panel CANNOT be installed under a tree, it requires sun to charge and maintain the batteries.
2. A solar system is often maintenance free BUT the batteries may require an occasional external charge in the winter months due to lack of sun.
3. Constantly powered accessories such as wired keypads will increase the standby current draw, solar panel or battery upgrades may be required if insufficient sun collection is not achieved.

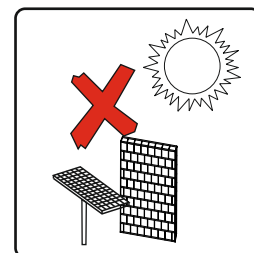
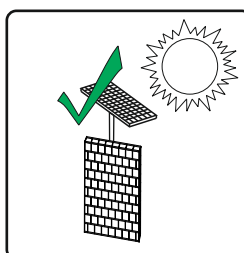
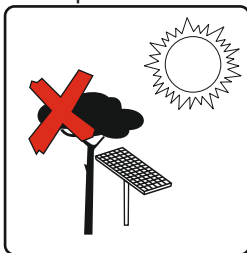

## Step 2: Mounting the APC UNO Solar Box

1. Install the bracket to the wall or post using the appropriate fixings whilst adhering to the maximum cable distance of 10m (note that the system is supplied with 6m).

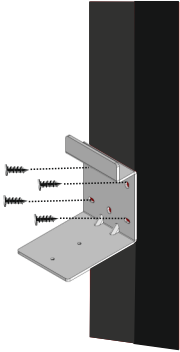

2. Position the solar box onto the installed bracket and secure in place using the two 4mm allen screws at the bottom.

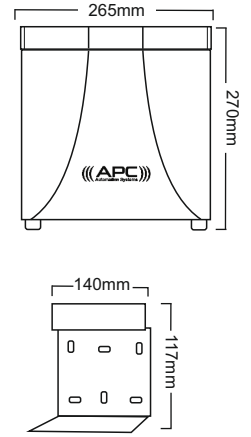
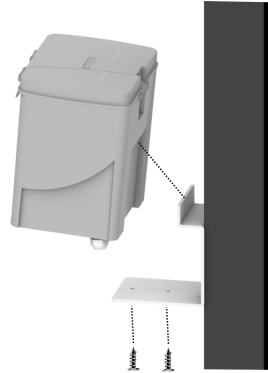

## 3. Wiring the System to the APC Sun Power

Taking into account that the solar panels maximum cable distance is 20 metres and the maximum distance between the solar box and the gate controller is 10 metres find a suitable location for the mounting of the box accordingly. Both the solar box and the solar panel are completely weatherproof and can be mounted in complete exposure to the elements.

1. Wire the positive and negative of the solar panel to their corresponding terminals.
2. Wire the batteries in series to create a 24V arrangement into the system and wire into the corresponding terminals. Regulator positive direct to battery 1, Regulator negative direct to battery 2, link the remaining terminal of each battery together.
3. Wire the regulators load outputs to the control boards green to the 24V DC INPUT moulded connector.
4. Plug the 24V DC Input Connector into the control board once ALL wiring works are completed.

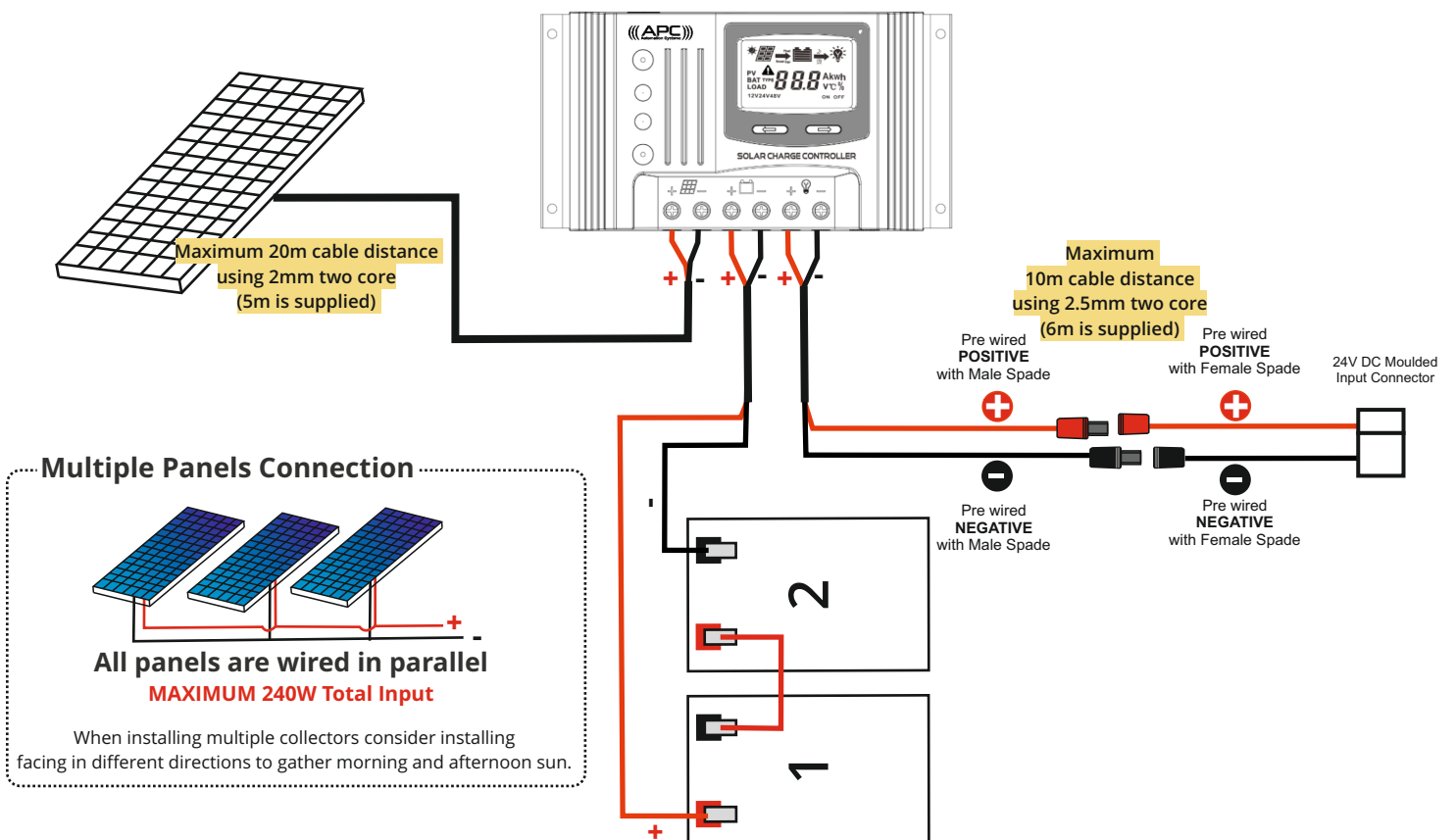

## Step 4: Configuring the system for Energy Saving Mode

Used to reduce the current consumption of the system down to just 5mA whilst in standby enabling this feature will turn off the display of the system 30 seconds after any operating cycle or 30 seconds of being in a standby state.

Note: Energy saving mode also disables the accessories power output, this will affect induction loops, GSM systems, WiFi controllers etc. In such situations the battery system of should be selected carefully as the standby current is 30mA.

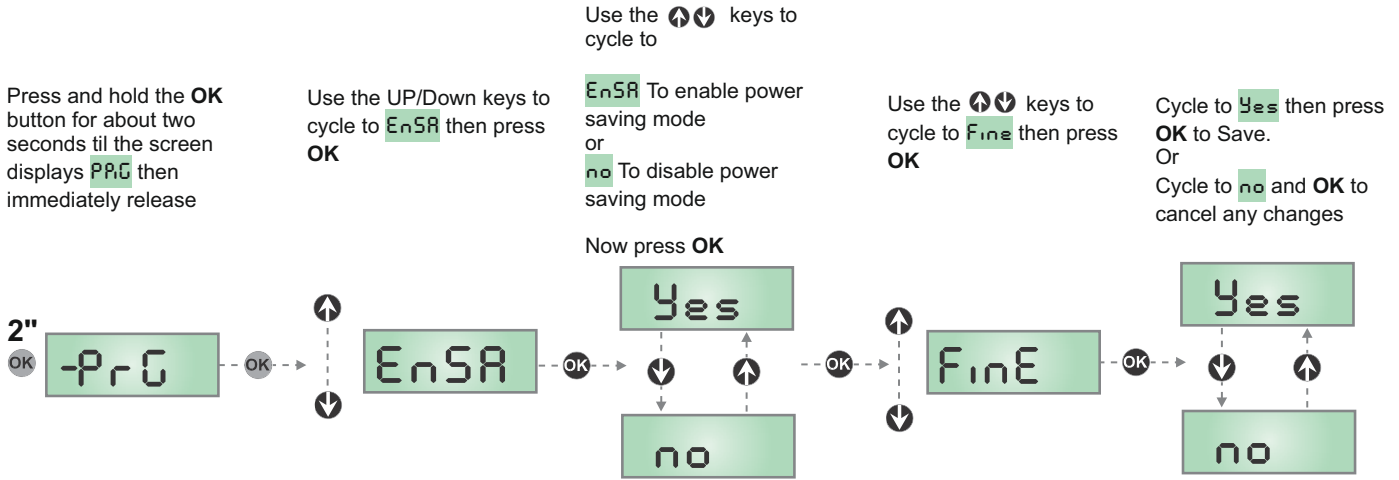

## Setting the OPENING direction

Setting the opening direction is a critical step in the installation process allowing the gate system and all its logic system to function correctly.

### Opening to the Left (SX)

### Opening to the Right (DX)

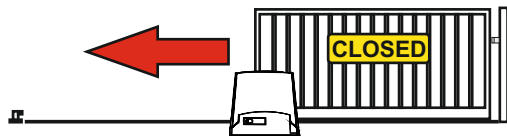

Use the keys to cycle to

Press and hold the **OK** button for about two seconds til the screen displays **PPC** then immediately release

Use the UP/Down keys to cycle to **dir** then press **OK**

**dH** for gates opening to the right or **SH** for gates opening to the left

Use the keys to cycle to **FinE** then press **OK**

Cycle to **Yes** then press **OK** to Save. Or Cycle to **no** and **OK** to cancel any changes

Now press **OK**

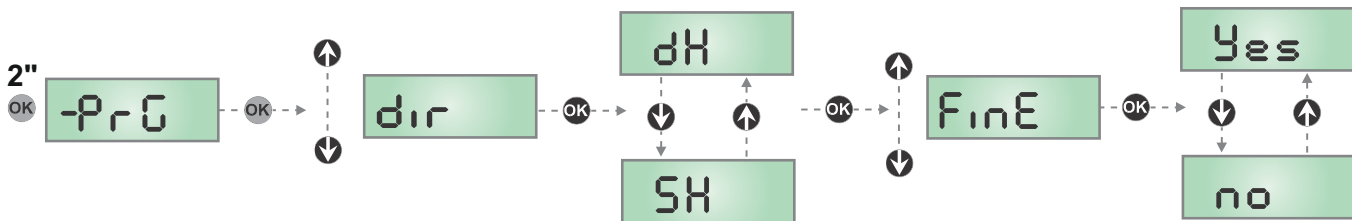

## Gate System SETUP Cycle

The purpose of the SETUP cycle is so that the gate control panel can learn its opening and closing limits and learn its slowdown. If the control panel is not setup it may run inconsistently and/or may not reach its stopping points and/or slowdown incorrectly.



- Ensure gear rack is not binding with **ZERO** resistance
- Ensure gate is free of ALL bowing
- Ensure that the motor is firmly fixed
- Ensure that the connections are all correct with no loose wire strands
- Ensure that Sx and Dx magnets are set correctly
- Ensure that the motor operating direction is set correctly

- 1 Press and hold the **OK** button for about six seconds til the screen displays **-SET** then immediately release

Use the UP/Down keys to cycle to **APP** then press **OK**

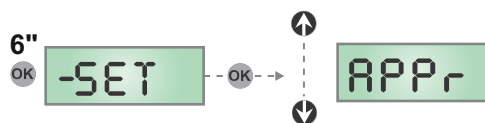

The **SETUP** cycle will now open and close the gate so that it can learn the travel distance. It will follow the sequence illustrated below.

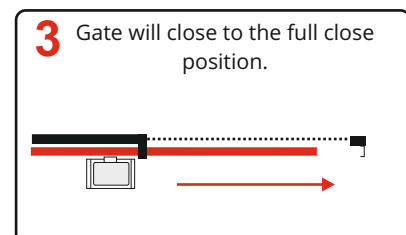
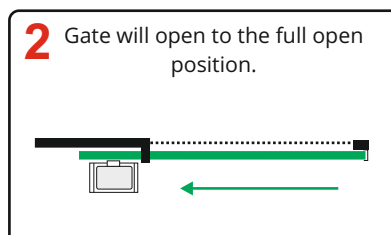
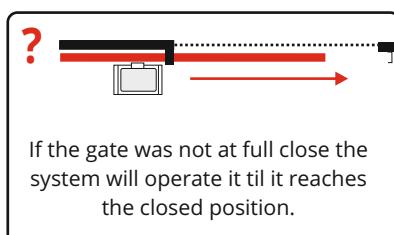

## Pairing & Deleting Wireless Items



### Clearing ALL wireless equipment

1. Turn OFF system power/disconnect 24V DC Power Input
2. Push and **HOLD** the button on the receiver and continue to hold, power on the system and continue to keep the button pressed. The led on receiver will illuminate for one second, then will blink four times, then will remain illuminated.
3. Release the button. The led will turn off, now the memory of the receiver is cleared.

### Clearing an INDIVIDUAL wireless item

1. Turn OFF system power/disconnect 24V DC Power Input
2. Push and **HOLD** the button on the receiver and continue to hold, power on the system and continue to keep the button pressed. The led on receiver will illuminate for one second, then will blink four times, before the fourth press release the button.
3. A five second window is open to press any button on the remote/wireless push button you wish to delete or type the correct code into the wireless keypad.

- Each time an item is deleted it restarts the five second window for additional individual items to be deleted.
- After five seconds of no activity the receiver will return to standby.

### Pairing Wireless Equipment

1. Push the button on the receiver for one second.
2. A five second window is open to press any button on the remote/wireless push button you wish to pair or type the correct code into the wireless keypad.

- Each time an item is paired it restarts the five second window for additional individual items to be paired
- After five seconds of no activity the receiver will return to standby.

### Service Free Pairing (Remote Controls ONLY)

1. Simultaneously press and **HOLD** button 1 and Button 2 on the remote.
  2. A five second window is open to press any button on the new remote you wish to pair.
- Each time an item is paired it restarts the five second window for additional individual items to be paired
  - After five seconds of no activity the receiver will return to standby.



## APC Remotes

### APC-RC4-SV

*Sun Visor Remote*

30 Metre Operational Range as is

OR Up to 100m using an ANT-1 Booster Antenna

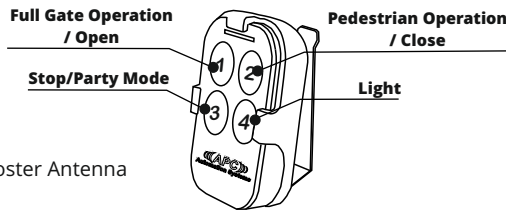

### APC-RC4S

*Keyring Remote*

20 Metre Operational Range as is

OR Up to 80m using an ANT-1 Booster Antenna

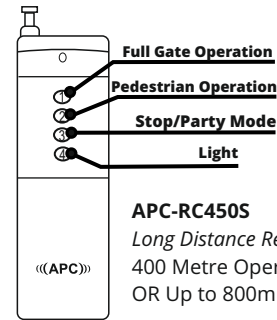
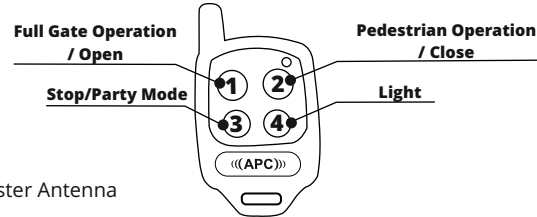

### APC-RC450S

*Long Distance Remote*

400 Metre Operational Range as is

OR Up to 800m using an ANT-1 Booster Antenna

## Party Mode

Party mode enables the user to keep the gate open by remote if there is an automatic close timer enabled. To keep the gate open press the STOP button on the remote (button 3) whilst the gate is counting down and it will remain open until the command to operate is given.

Press and **HOLD "3"** on the remote control for one second then release **WHILST** the gate is OPEN.

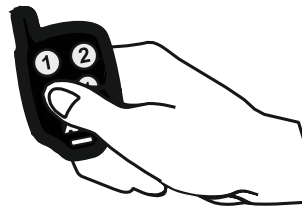

## Connecting an APC-ANT1 External Antenna

The ANT-1 external antenna can boost the remote range drastically in most installations.

- APC-RC450S remote can be boosted UP TO 800m distance
- APC-RC4-SV remote can be boosted UP TO 100m distance
- APC-RC4-S remote can be boosted UP TO 80m distance



Inner core of the antenna cable to ANT (A2) on the control board.

Outer core/shield of the antenna to ANT Shield (A1) on the control board.

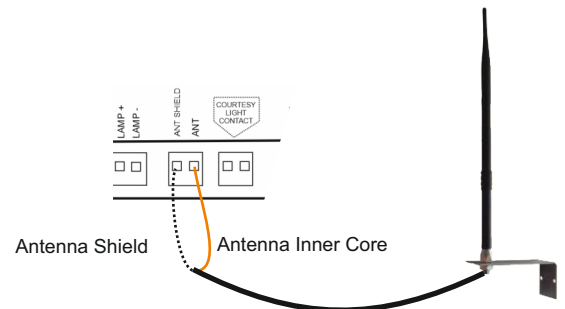

## Connecting an APC-ULA Light with External Antenna

The APC-ULA external antenna can boost the remote range substantially with the added feature of a safety light.

- APC-RC450S remote can be boosted UP TO 600m distance
- APC-RC4-SV remote can be boosted UP TO 80m distance
- APC-RC4-S remote can be boosted UP TO 60m distance



Inner core of the antenna cable to ANT (A2) on the control board.

Outer core/shield of the antenna to ANT Shield (A1) on the control board.

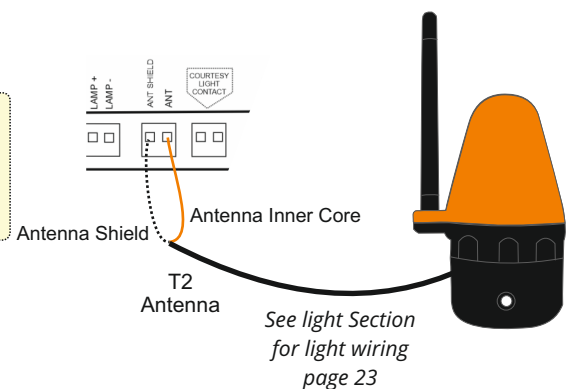

# APC Smart Wireless Button Configuration

**PBD-KW**  
(Double Push Button Switch)

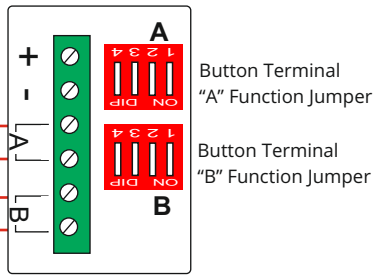
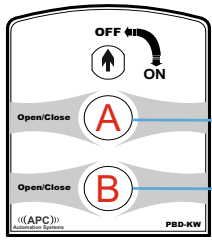

**PBS-KW**  
(Single Push Button Switch)

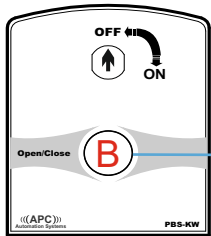

## Setting

Using the DIP switch associated with the button in use (see linked diagrams on the left). You can adjust your DIP switch to enable it to toggle a specific feature. Simply turn the respective DIP switch to the ON position.

**Max. 20 Metre Operational Range\***

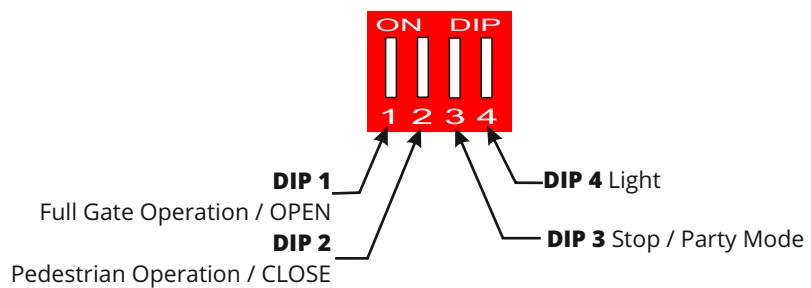

## APC-KP2W Pin number programming (4 Digit)

The APC-KP2W has TWO channels, each channel can control a different function on the system. To continue adding pin numbers after adding the first repeat the steps below.

**Note:** When you add your first pin number to each channel the default pin code will automatically be erased.

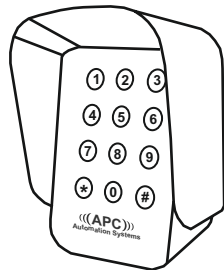

Type in the 4 digit pin code then press #

**Default:**

- 1111# For Full Gate Opening / OPEN
- 2222# For Pedestrian Opening / CLOSE

**Max. 20 Metre Operational Range\***

## Quick Programming Pin Code

**Channel 1**  
**Full Operation / OPEN**  
(Supports 8 Pin Codes)

Master Code \*  
0 1 #  
Pin Code #

**Channel 2**  
**Pedestrian Operation / CLOSE**  
(Supports 3 Pin Codes)

Master Code \*  
0 2 #  
Pin Code #

# APC Wired Push Button Connection

Push buttons are used for opening and closing the gates without using a remote.

Push buttons can be used for a vast amount of purposes ranging from basic access control for visitors, workers or taking out the bins.

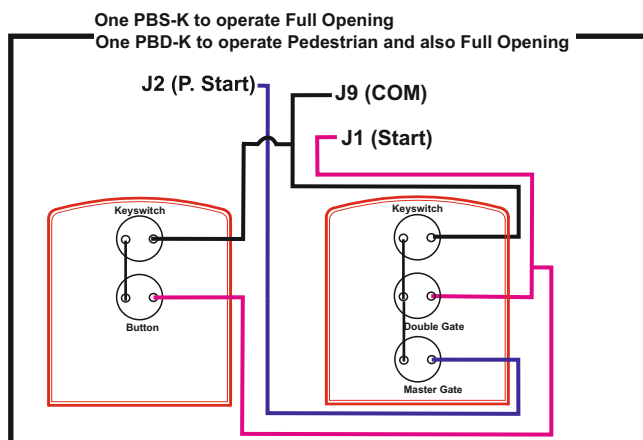
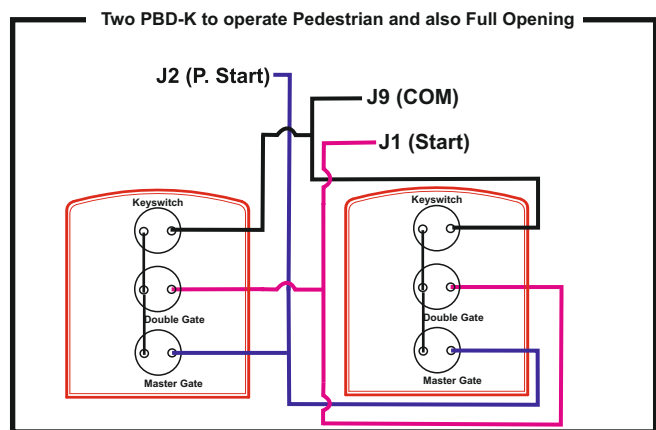
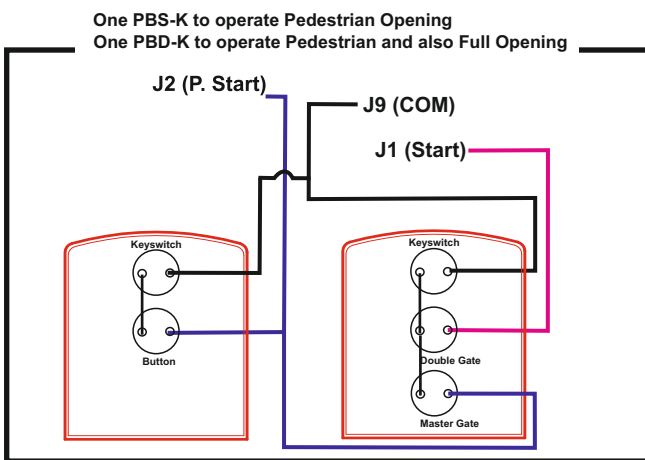
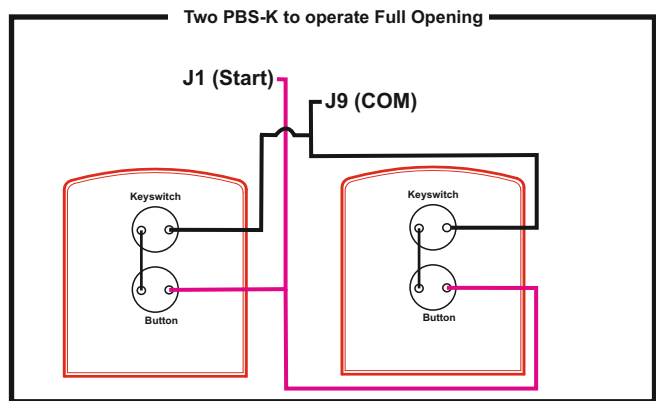
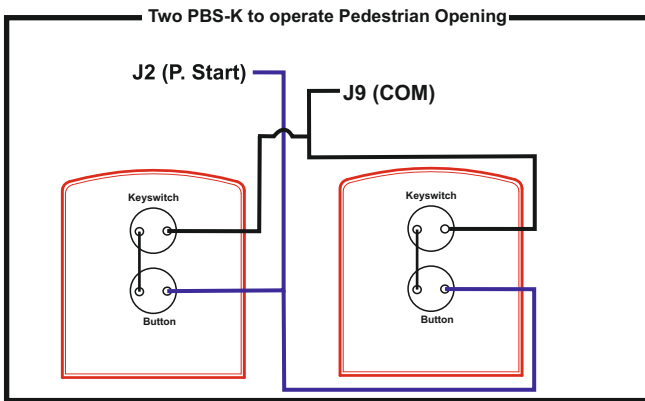
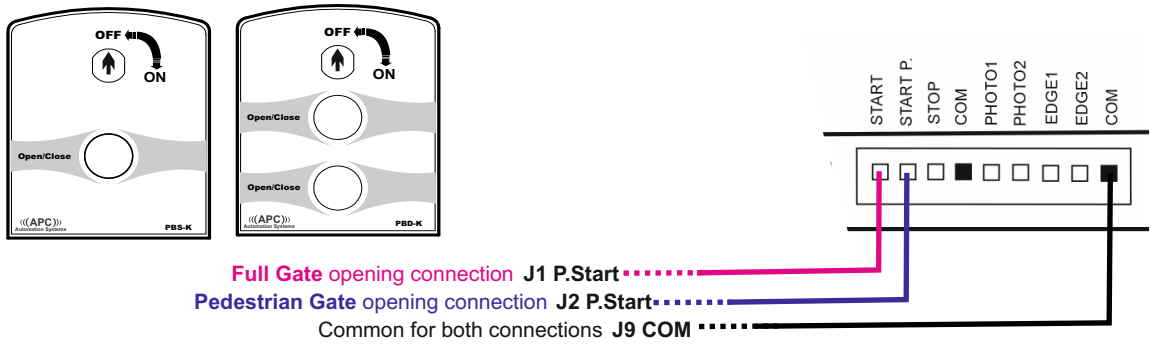

## Connecting an APC Keypad (APC-KP1-C)

Unlike a push button entry switch using a keypad can provide a much higher security for access control for guests, workers, tenants etc.

Using a keypad will allow you to manage the users by adding and deleting as required. Its backlit illumination also allows for ease of use at night.

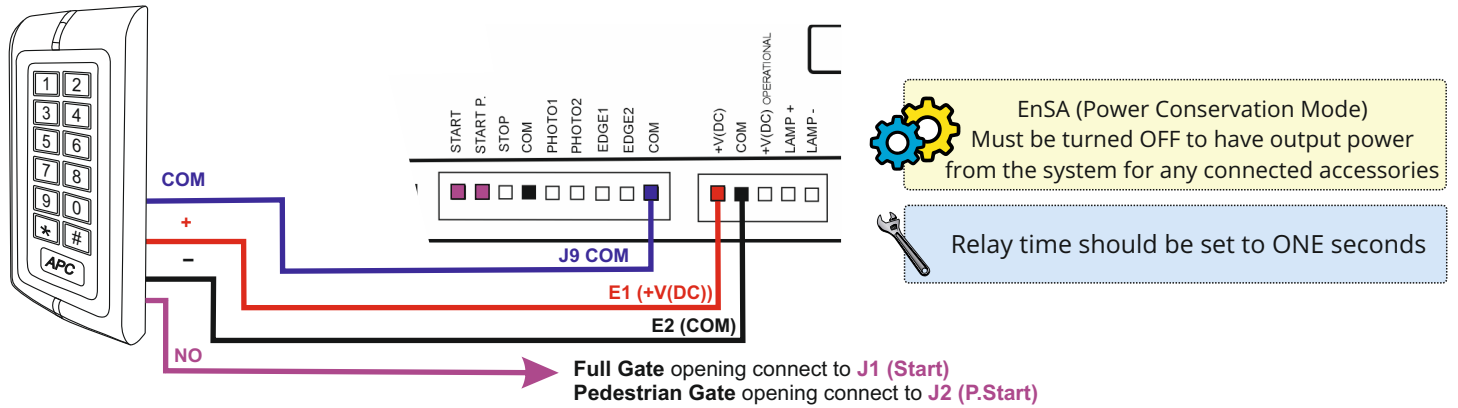

### Quick Programming Pin Code / Swipe Tag

\* 8 8 8 8 8 8 #  
1  
User ID #  
PIN/SWIPE #  
\*  
\*

Master Code used to enter programming only

To enter Pin Code/Swipe Card Programming

Any number between 1-999, this number is unique to each pin code/swipe tag and cannot be used twice

The Pin code you would like to use to open the gate (4-6 Digits) OR Swipe the tag past the black window

To Exit programming and return to standby state

## Connecting an APC Mondo Wi-Fi Keypad (APC-WF-KP)

Unlike a push button entry switch using a keypad can provide a much higher security for access control for guests, workers, tenants etc.

Using a keypad will allow you to manage the users by adding and deleting as required. Its backlit illumination also allows for ease of use at night.

Furthermore the keypad can be connected to your Wi-Fi network and can be controlled anywhere in the world through the APP.

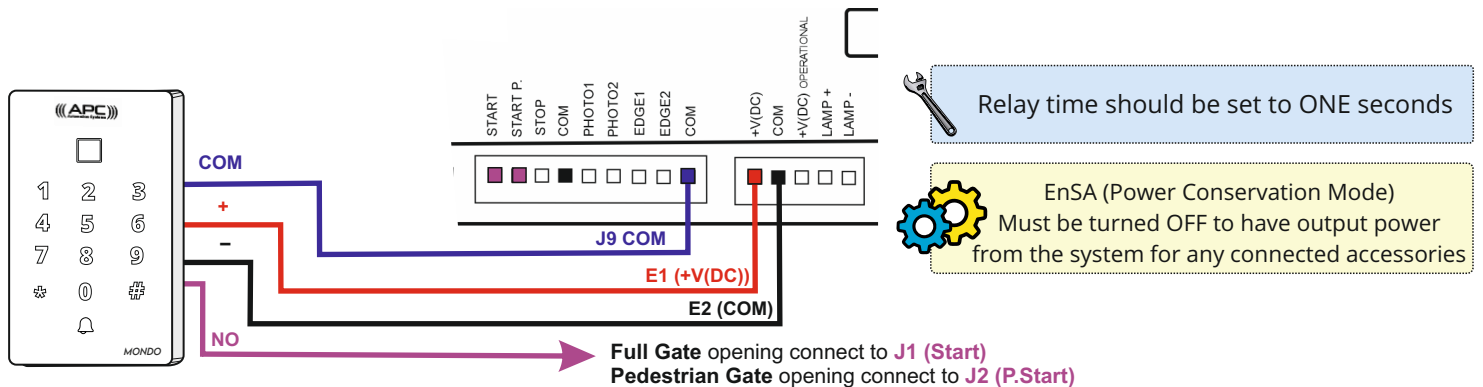

### Quick Programming Pin Code / Swipe Tag

\* 9 9 9 9 9 9 #  
1  
User ID #  
PIN/SWIPE #  
\*  
\*

Master Code used to enter programming only

To enter Pin Code/Swipe Card Programming

Any number between 1-999, this number is unique to each pin code/swipe tag and cannot be used twice

The Pin code you would like to use to open the gate (4 Digits) OR Swipe the tag past the red square

To Exit programming and return to standby state

## APC Connect4 GSM Reciever

A GSM Receiver is the absolute most flexible form of access control. Providing there is good mobile reception at the gate the GSM switch can operate the gate from anywhere in the world. When receiving a call it will automatically reject the call and open or close the gate. SIM CARD IS NOT SUPPLIED.



EnSA (Power Conservation Mode) Must be turned OFF to have output power from the system for any connected accessories



Relay time should be set to ONE seconds

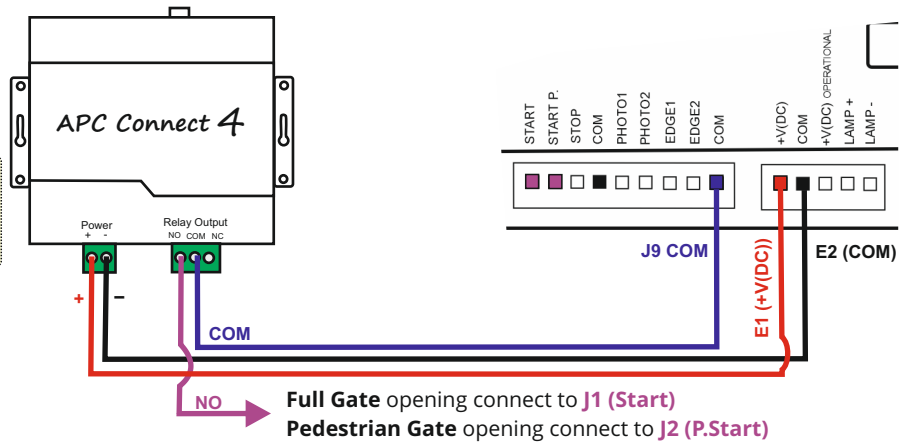

## APC WF-CH1 Wi-Fi Switch

The Wi-Fi switch allows use of the gate system from anywhere in the world by APP, it can also hold schedules for automatic operation of the gate. It can be controlled by Google Home as well as Amazon Alexa.



EnSA (Power Conservation Mode) Must be turned OFF to have output power from the system for any connected accessories



Relay time should be set to THREE seconds

Full Gate opening connect to J1 (Start)  
Pedestrian Gate opening connect to J2 (P.Start)

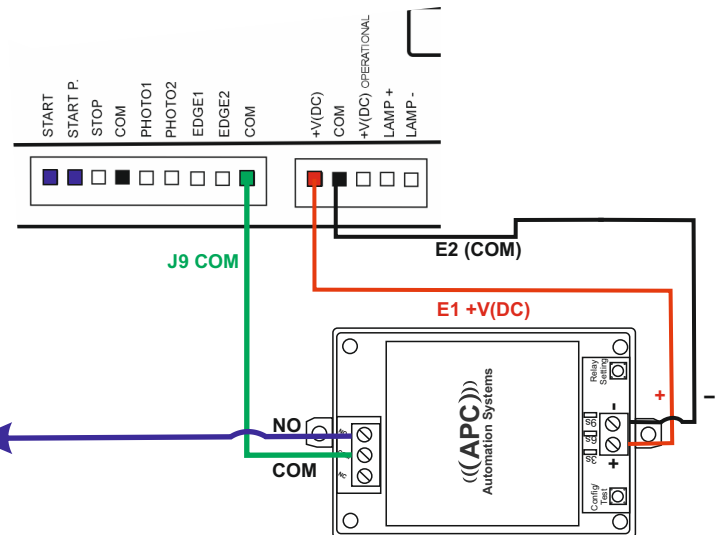

## Eyevision® Intelli Series Intercom

The intelli intercom range will allow you to see your visitors when they ring the doorbell wether on screen or by the APP and also control the operation of the gate.



EnSA (Power Conservation Mode) Must be turned OFF to have output power from the system for any connected accessories



Relay time should be set to ONE seconds

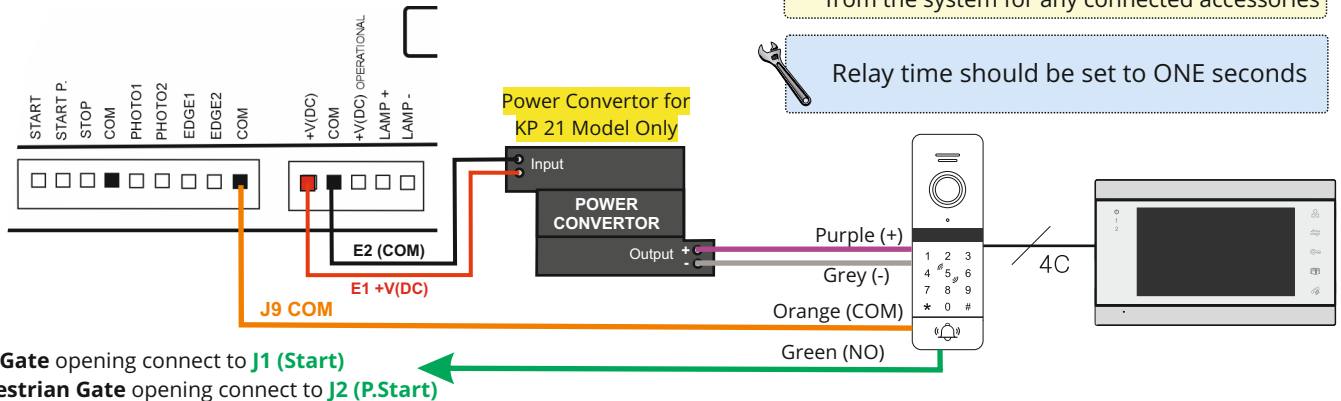

## Connecting a Retro Reflective Sensor (APC-RR-11)

APC-RR-11 Reflective sensor (Transmitter only) **must be connected back to the control board** (see wiring diagram).  
Install the RR-11 Reflective sensor on the first entry point of the driveway from post to post at approx. 500mm above ground level.

**The Transmitter and the Reflector must be inline with each other**  
(The yellow inline LED will be ON when Aligned with the transmitter).



If Using EnSA energy saving mode  
Ensure the Photocell  
"Check before motion" is enabled

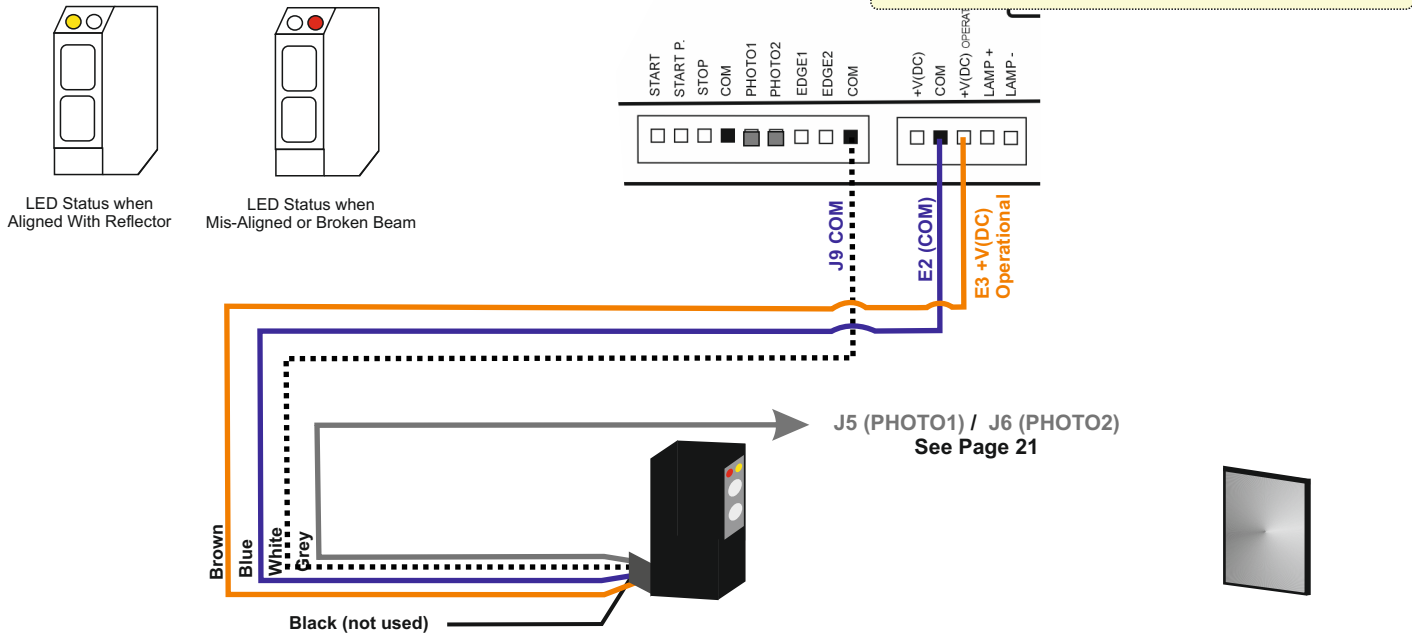

## Connecting a PE Sensor (APC-PE2000)

APC-PE2000 PE sensor (Transmitter & Receiver) must be connected back to the control panel.  
Install the PE2000 Photoelectric sensor on the first entry point of the driveway from post to post at approx. 500mm above ground level.

**The Transmitter and the Receiver must be inline with each other**  
(The inline LED will be off when aligned with the transmitter).



If Using EnSA energy saving mode  
Ensure the Photocell  
"Check before motion" is enabled

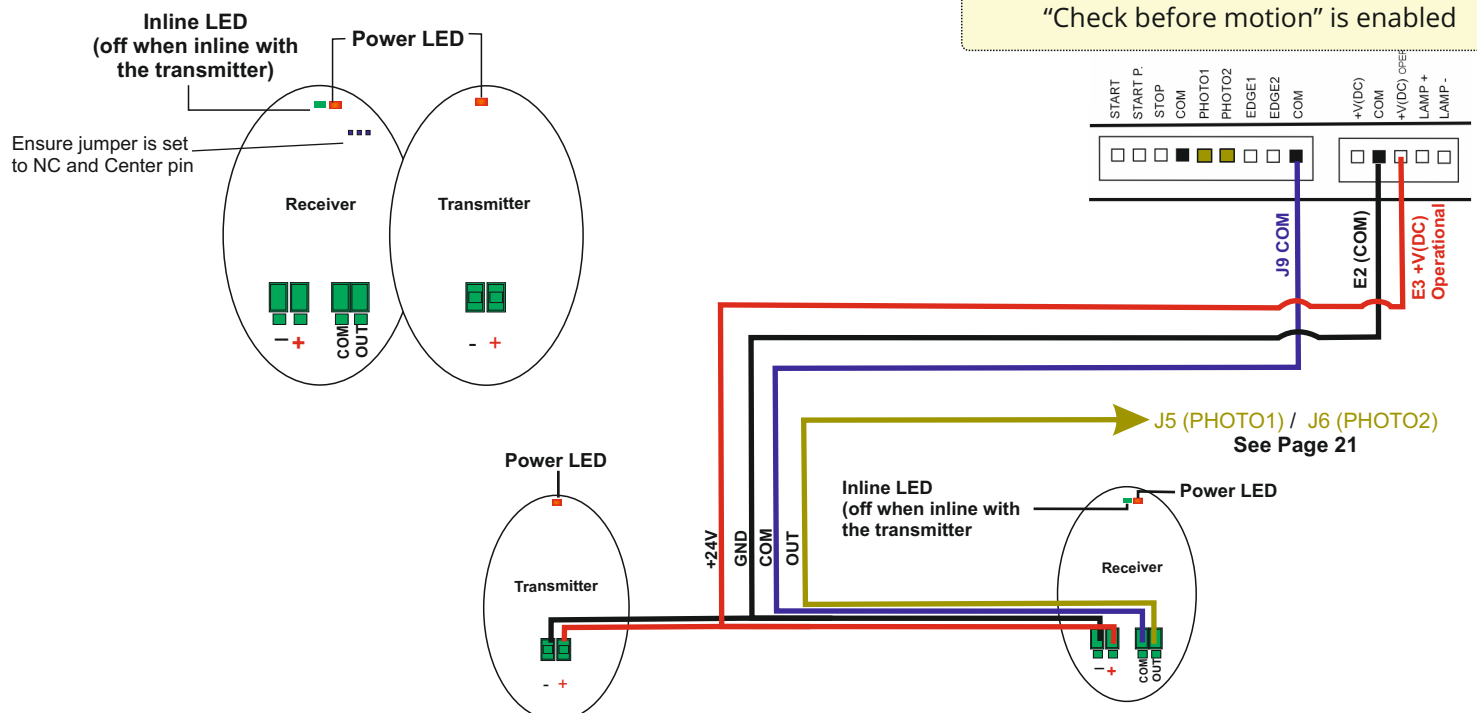

# Enabling the photocell and setting the logic



"Check before motion" for Photocell

Default is OFF

Prior to enabling the photocell you will first need to choose the logic system in which it will operate.  
**FOT1** Logic will function during both the opening and closing cycles (check can be enabled prior to beginning either cycle).  
**FOT2** Can be set to function in closing or in closing along with a check prior to beginning the closing cycle.

## FOT2 Logic (PHOTO 2 Input)

Press and hold the **OK** button for about two seconds for about two seconds til the screen displays **PrG** then immediately release

Use the UP/Down keys to cycle to **Fot2** then press **OK**

Use the **UP/DN** keys to cycle to the required logic based on the above options.  
**CFCh** Closing direction + check before motion of starting the close cycle  
**Ch** Closing direction only  
**no** Disabled

Use the **UP/DN** keys to cycle to **FinE** then press **OK**

Cycle to **Yes** then press **OK** to Save.  
 Or  
 Cycle to **no** and **OK** to cancel any changes

Now press **OK**

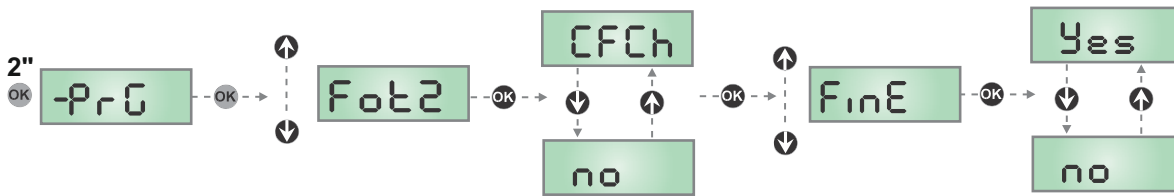

## FOT1 Logic (PHOTO 1 Input)

Press and hold the **OK** button for about two seconds til the screen displays **PrG** then immediately release

Use the UP/Down keys to cycle to **Fot1** then press **OK**

Use the **UP/DN** keys to cycle to the required logic based on the above options.

**APCh** Enabled  
**no** Disabled

Now press **OK**

Now the photocell testing before operation needs to be turned on, cycle to **PfE.tE** then press **OK**

Use the **UP/DN** keys to cycle to **Yes** to enable the check.

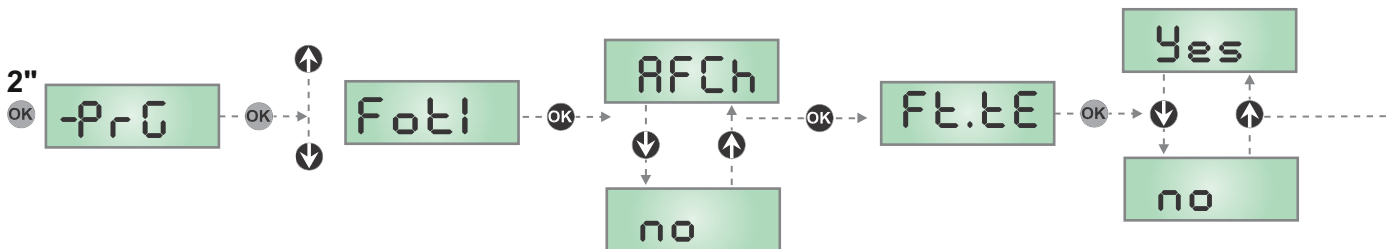

Use the **UP/DN** keys to cycle to **FinE** then press **OK**

Cycle to **Yes** then press **OK** to Save.  
 Or  
 Cycle to **no** and **OK** to cancel any changes

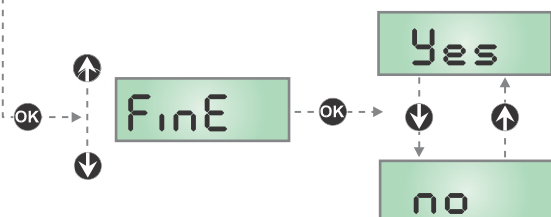

## Automatic Closing for Full Gate Operation

Default is Off

The full gate operation automatic close timer can be configured for anywhere from 5 second up to 20 minutes in 5 second increments. Note the symbol for seconds is " and for minutes is '.

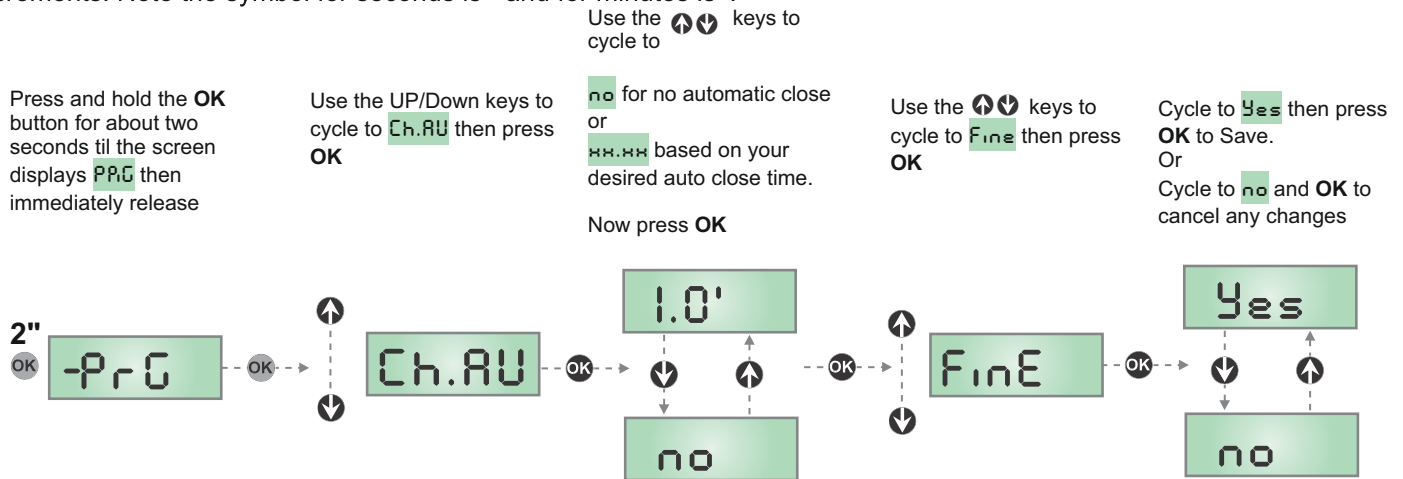

## Automatic Closing for Pedestrian Function

Default is Off

The pedestrian gate operation automatic close timer can be configured for anywhere from 5 second up to 20 minutes in 5 second increments. Note the symbol for seconds is " and for minutes is '.

The pedestrian gate automatic close timer begins from the last movement through the photocells and restarts each time accordingly every time there is a moment through the photocells.

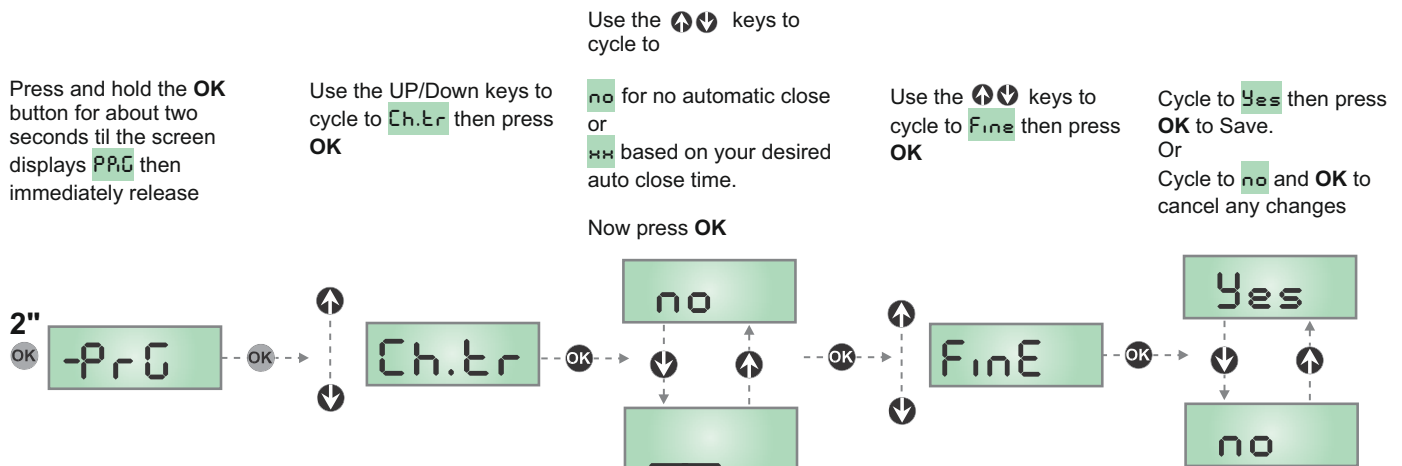

## Automatic Closing after stopping the full gate operation

Default is Off

In the case where a user has stopped the gate part way though a full gate operation cycle the system can still be set to auto close from this position by enabling the feature using the command below. Once enabled it will use the same time that has been set for pedestrian gate auto close time.

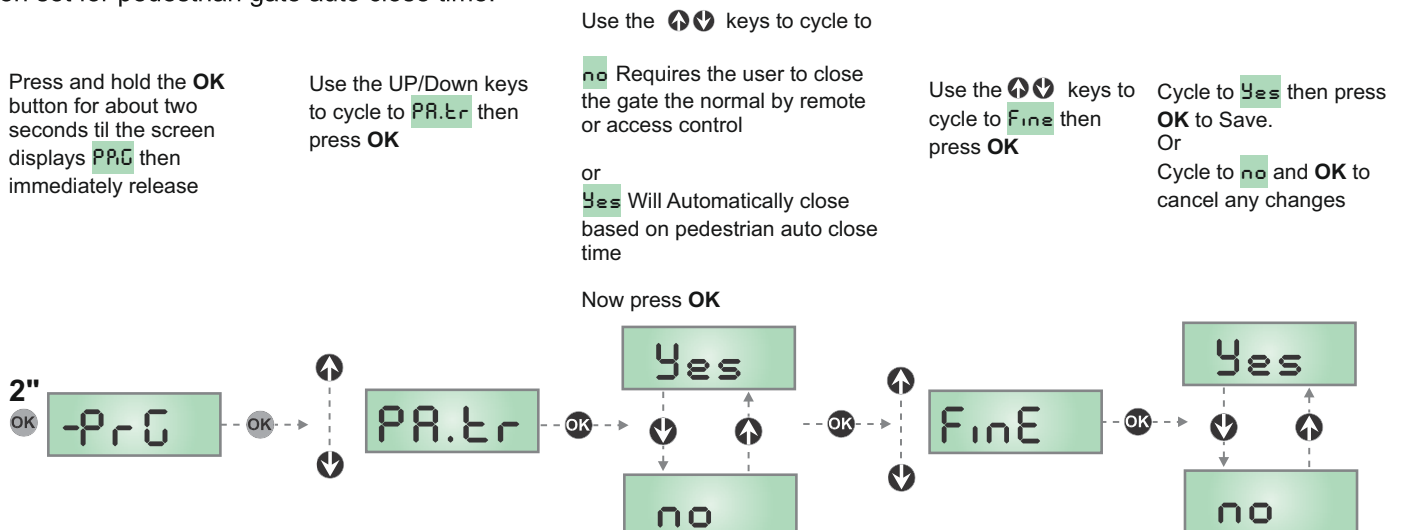



## Connecting an APC-ULA Safety Lamp

Warning lights are used to alert pedestrians to be cautious as there may be vehicles entering and exiting.

**Note:** Ensure that the light is set to constant illumination mode (not flashing) as this can be set from the logic parameters below.



**THIS OUTPUT IS NOT FOR DRIVEWAY LIGHTS**  
see driveway light section page 29



This internal relay will support an output of 24V 3W Maximum



EnSA (Power Conservation Mode) Must be turned OFF to have output power from the system for any connected accessories

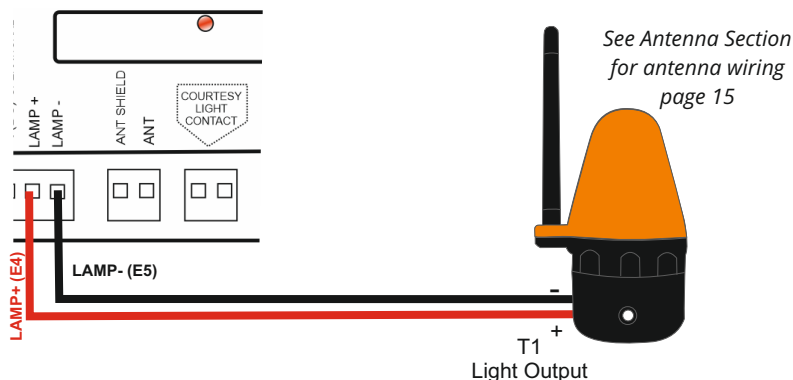

## Setting the Lamp Output

Default is Flashing

The lamp output can be set to OFF, Flashing at one rate (Slow 20HZ) or Conditional flashing based on the current status.

### Conditional Flashing status:

Gate stopped (Lamp OFF)

Gate in auto close count down (the lamp is Continuously on)

Gate Opening (Slow 2HZ blinking)

Gate Closing (Fast 4HZ Blinking)

Press and hold the **OK** button for about two seconds til the screen displays **PrG** then immediately release

Use the UP/Down keys to cycle to **SPIR** then press **OK**

Use the **UP/DN** keys to cycle to

**no** for OFF  
**FLSH** for fixed frequency flashing  
**W.L.** for conditional flashing

Use the **UP/DN** keys to cycle to **FinE** then press **OK**

Cycle to **Yes** then press **OK** to Save.  
Or  
Cycle to **no** and **OK** to cancel any changes

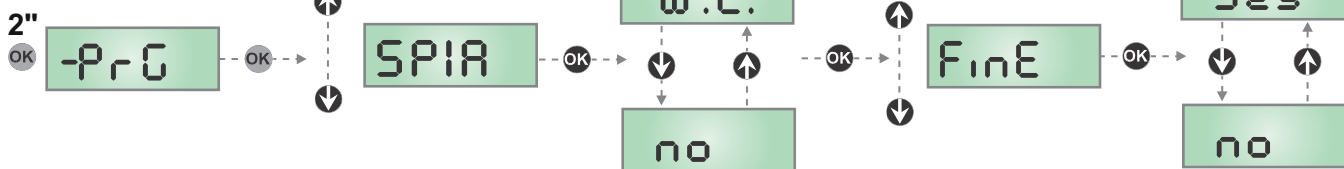

## Enable Blinking During Auto Close Countdown

Default is OFF

Press and hold the **OK** button for about two seconds til the screen displays **PrG** then immediately release

Use the UP/Down keys to cycle to **LP.PR** then press **OK**

Use the **UP/DN** keys to cycle to

**no** for OFF  
**Yes** for ON

Now press **OK**

Use the **UP/DN** keys to cycle to **FinE** then press **OK**

Cycle to **Yes** then press **OK** to Save.  
Or  
Cycle to **no** and **OK** to cancel any changes

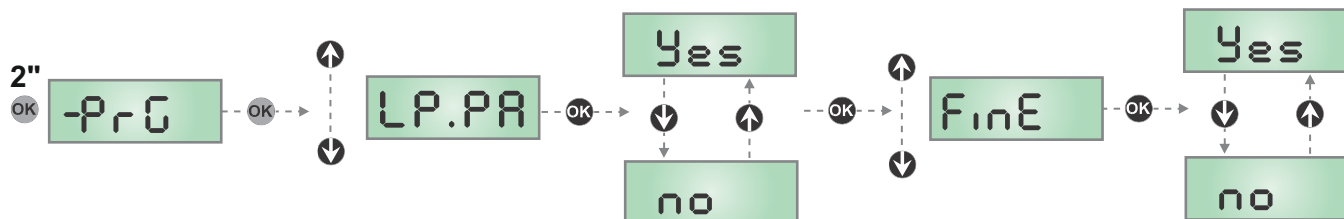

## Induction Loops

Before connecting it is important to note that the system must be set to function for induction loops on a logic level, see below the recommended list of parameters.

Furthermore at minimum a photocell must be installed and the automatic close timer must be enabled.

### APC Loop Detector For Auto Gate Opening

The APC Loop Detector will detect vehicles over the induction loop and automatically operate the gates to open.



EnSA (Power Conservation Mode)  
Must be turned OFF to have output power from the system for any connected accessories



Ensure the Photocell and Safety Edge  
"Check before motion" is enabled

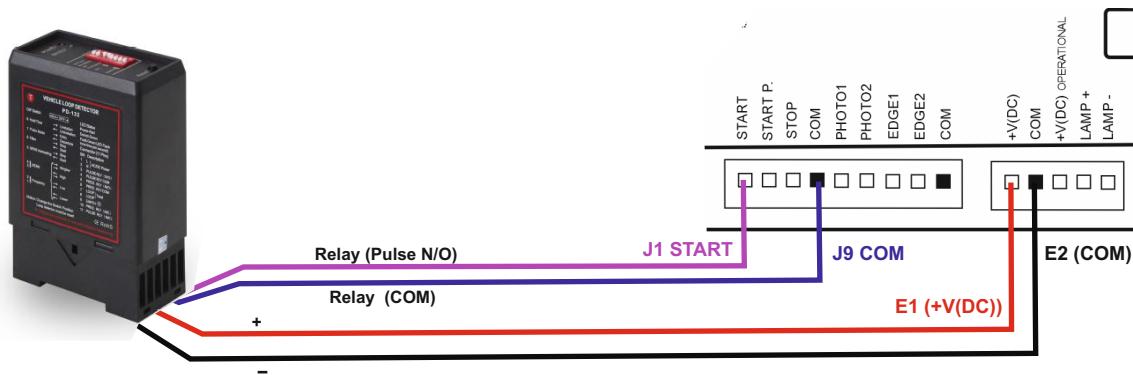

The below are the recommended setting when using an induction loop or a timer, these commands will change the logic of the **START J1** Input as follows:

**St.Et** should be set to **orOL** to enable the function of full timer mode

**St.oP** should be set to **no**, Stop input will be ignored

**St.AP** should be set to **no**, this will ignore commands whilst opening

**St.CH** should be set to **RPEr**, this will revert the gate to open if a command is given during closure

**St.PR** should be set to **PRUS** to reset the automatic closing time when a command is given

### APC Loop Detector For Inhibition

The APC Loop Detector will detect vehicles over the induction loop and stop the gate.



EnSA (Power Conservation Mode)  
Must be turned OFF to have output power from the system for any connected accessories



Ensure the Photocell and Safety Edge  
"Check before motion" is enabled

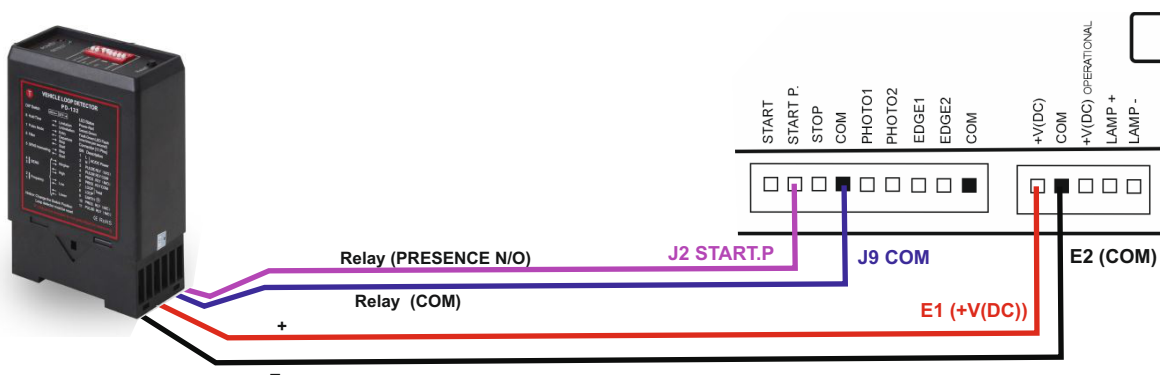

The below are the recommended setting when using an induction loop or a timer, these commands will change the logic of the **START.P J2** Input as follows:

**St.Et** should be set to **orOL** to enable the function of full timer mode

**P.RPP** should be set to **0**, this will hold the gate open and prevent automatic closure during circuits present times.

## Standard mode **StEn**

START = START (a command will cause the complete opening of the gate)

START P. = PEDESTRIAN START (a command will cause the partial opening of the gate)

## Open/Close command **RP.Ch**

START = OPENING (always controls the gate opening)

START P. = CLOSING (always controls the gate closing) This is an impulse command, that is to say that an impulse will cause the complete gate opening or closing.

**(Button 1 on remote/Start is open, button 2 on remote/Start.P is closing)**

## Manned operation **PrES**

START = OPENING (always controls the gate opening)

START P. = CLOSING (always controls the gate closing) This is a monostable command, that is to say, the gate will be opened or closed as long as the contact is closed and it will immediately stop as the contact is open

## Full Timer mode **orol** Using an external timer to open gate, timers latched circuit inhibits the gates closure

### ATTENTION: Automatic closing must be enabled

This feature allows you to program time slots during the day for the gate to be open by using an external timer or other maintained command devices (e.g. magnetic loop detectors or presence detectors).

START = START (a command will cause the complete opening of the gate)

START P. = PEDESTRIAN START (a command will cause the partial opening of the gate)

The gate stays open (completely or partially) while the contact is closed on input; as soon as the contact is open the pause time count down will start, after which the gate will be closed again.

**NOTE: If the parameter of partial operation/pedestrian function **P.APP** is set to 0% =** The timer connected to START P. does not cause the opening, but can inhibit the automatic closing at preset times.

In all modes, inputs must be connected to devices having normally open contacts.

Connect cables of device controlling the START input between terminals **J1 (START)** and **J4 (COM)** of the control unit. Connect cables of device controlling the START P. input between terminals **J2 (START P.)** and **J4 (COM)** of the control unit.

Press and hold the **OK** button for about two seconds til the screen displays **PrG** then immediately release

Use the UP/Down keys to cycle to **StEn** then press **OK**

Use the **↕** keys to cycle to  
Select the logic based on the above.

Use the **↕** keys to cycle to **FinE** then press **OK**

Cycle to **Yes** then press **OK** to Save.  
Or  
Cycle to **no** and **OK** to cancel any changes

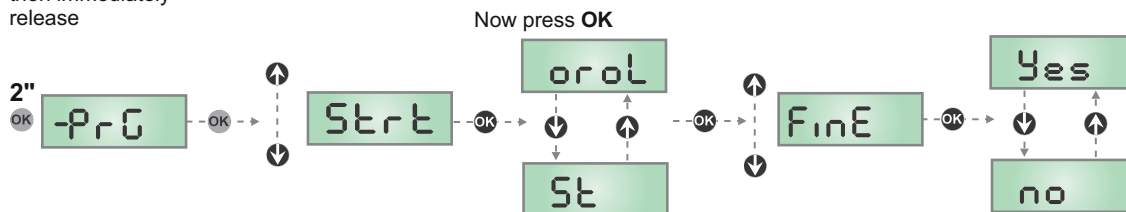

## Pre Flashing Time (Open and Close)

Default is 1 second

Pre flashing time allows for the connected lamp to begin flashing PRIOR to the operating cycle based on the time you set. The minimum time is 0.5 seconds and maximum is 1 minute.

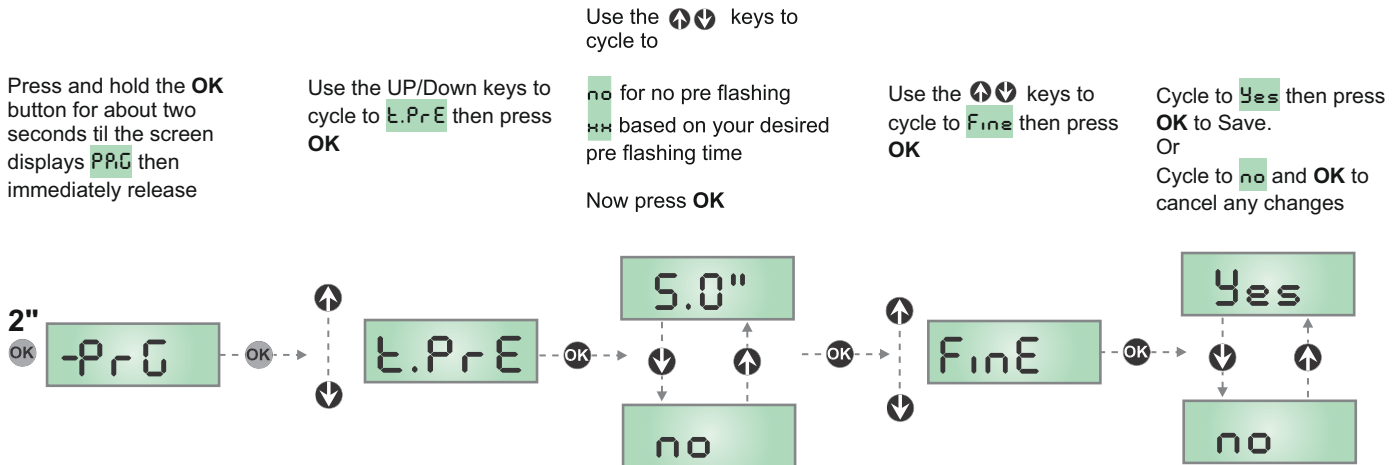

**Note 1:** Times set for pre-flashing will delay the gate from beginning its opening operation by the set value

**Note 2:** Times set for pre-flashing will delay the gate from beginning its closing operation by the set value after the Auto close time has elapsed, it can be adjusted to be OFF or increased in the closing pre-flash time setting.

## Adjusting the Closing Pre Flashing Time

Default is Off

Used for situations where it would be ideal to set a longer time to the opening pre flashing as a courtesy to others that the gate will be closing soon.

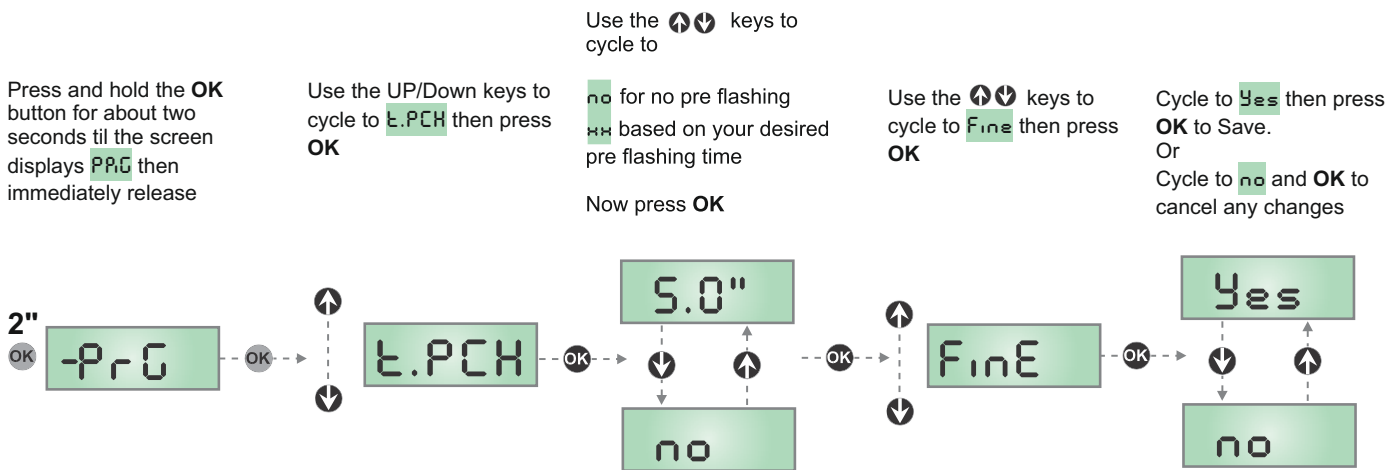

**Note:** Times set for pre-flashing will delay the gate from beginning its closing operation by the set value after the Auto close time has elapsed.

## Manually adjusting the over current sensing

Default is no

If NO is selected the system will automatically obstacle sense based on encoder settings however if a manual adjustment is required the system can manually be configured for an adjustment from 1.0A up to 18.0A.

Press and hold the **OK** button for about two seconds til the screen displays **PrG** then immediately release

Use the UP/Down keys to cycle to **SEnS** then press **OK**

Use the  $\uparrow/\downarrow$  keys to cycle and adjust over current amps

Use the  $\uparrow/\downarrow$  keys to cycle to **FinE** then press **OK**

Cycle to **Yes** then press **OK** to Save.  
Or  
Cycle to **no** and **OK** to cancel any changes

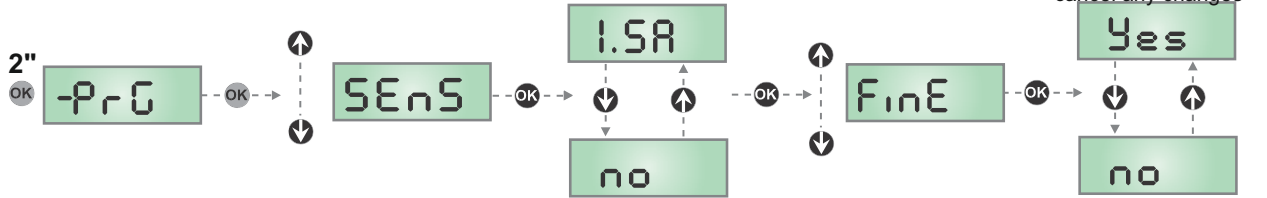

## Adjusting the encoder sensitivity

Default is 0

Encoder sensitivity can be set from 0 (minimum sensitivity) to a maximum of 7 (most sensitive), it should be considered that 0 sensitivity is a complete physical stop of the gate and any increase will be more sensitive.

Press and hold the **OK** button for about two seconds til the screen displays **PrG** then immediately release

Use the UP/Down keys to cycle to **S.Enc** then press **OK**

Use the  $\uparrow/\downarrow$  keys to cycle and adjust the encoder sensitivity.

Use the  $\uparrow/\downarrow$  keys to cycle to **FinE** then press **OK**

Cycle to **Yes** then press **OK** to Save.  
Or  
Cycle to **no** and **OK** to cancel any changes

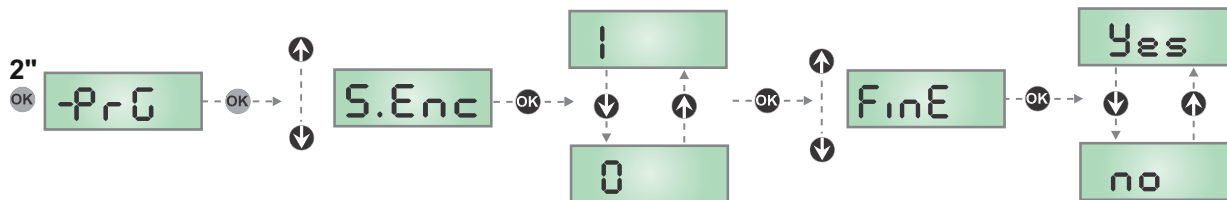

## Adjusting the motor power for fast operating speed

Default is 60

The displayed value is the current power setting, it is adjustable from 30(%) to 100(%).

Press and hold the **OK** button for about two seconds til the screen displays **PrG** then immediately release

Use the UP/Down keys to cycle to **Pot** then press **OK**

Use the  $\uparrow/\downarrow$  keys to cycle to  
Select the power %  
Now press **OK**

Use the  $\uparrow/\downarrow$  keys to cycle to **FinE** then press **OK**

Cycle to **Yes** then press **OK** to Save.  
Or  
Cycle to **no** and **OK** to cancel any changes

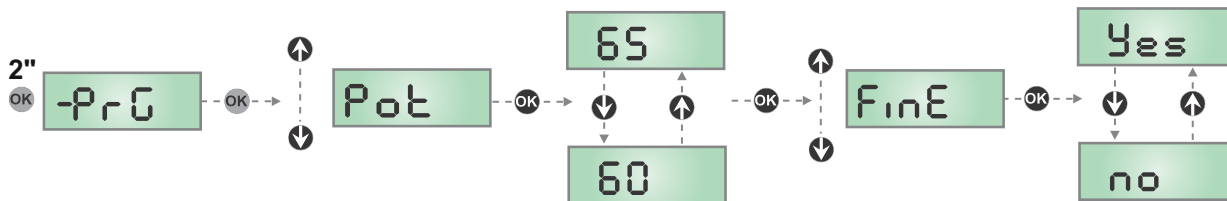

## Adjusting the motor power for slow operating speed

Default is 20

The displayed value is the current power setting, it is adjustable from 0(%) to 70(%).

Press and hold the **OK** button for about two seconds til the screen displays **PrG** then immediately release

Use the UP/Down keys to cycle to **P.ral** then press **OK**

Use the  $\uparrow/\downarrow$  keys to cycle to  
Select the power %  
Now press **OK**

Use the  $\uparrow/\downarrow$  keys to cycle to **FinE** then press **OK**

Cycle to **Yes** then press **OK** to Save.  
Or  
Cycle to **no** and **OK** to cancel any changes

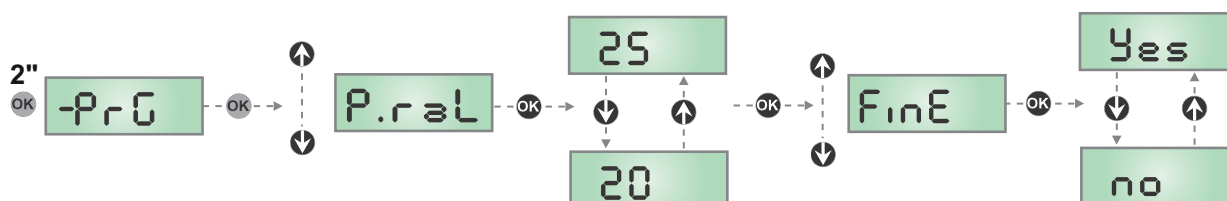

## Disable the Ramp Up Feature

Default is no

If enabled (yes) then the motor will run at maximum power for the startup procedure.

Press and hold the **OK** button for about two seconds til the screen displays **PrG** then immediately release

Use the UP/Down keys to cycle to **SPUn** then press **OK**

Cycle to **Yes** then press **OK** to disable up.  
Or  
Cycle to **no** and **OK** to enable ramp up.

Use the **↕** keys to cycle to **FinE** then press **OK**

Cycle to **Yes** then press **OK** to Save.  
Or  
Cycle to **no** and **OK** to cancel any changes

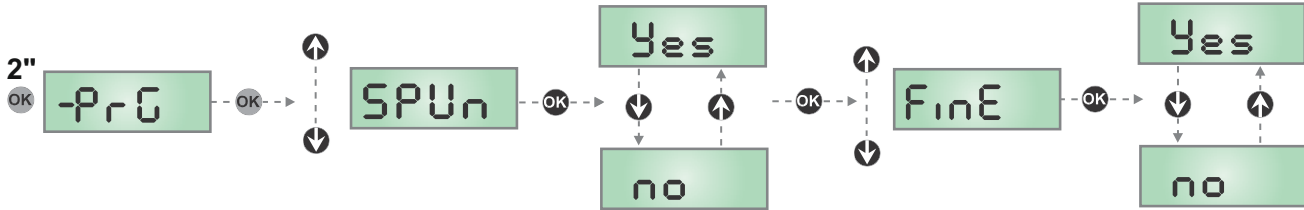

## Duration of the Ramp Up feature

Default is 2

If ramp up is enabled the duration (in seconds) can be adjusted to reach the full nominated power. This will help in reducing the sudden speed up of the gate if set to a higher power setting as it can be increased gradually over a longer duration. The maximum time is 6 seconds.

Press and hold the **OK** button for about two seconds til the screen displays **PrG** then immediately release

Use the UP/Down keys to cycle to **rAM** then press **OK**

Use the **↕** keys to cycle and adjust the duration

Use the **↕** keys to cycle to **FinE** then press **OK**

Cycle to **Yes** then press **OK** to Save.  
Or  
Cycle to **no** and **OK** to cancel any changes

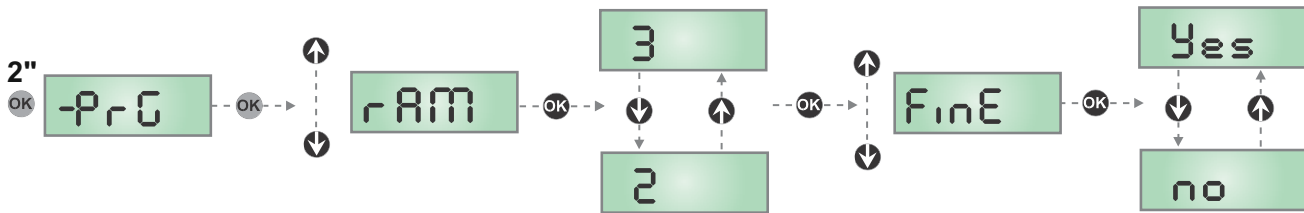

## Manually adjusting the slowdown distance for closing

Default is 15

The distance in % can be adjusted based on the cycle duration in which the slowdown will begin. For example if set to 15 then it will be the last 15% of the cycle. The adjustment is from 0% to 100%

Press and hold the **OK** button for about two seconds til the screen displays **PrG** then immediately release

Use the UP/Down keys to cycle to **rA.AP** then press **OK**

Use the **↕** keys to cycle and adjust the position of the slowdown by %

Use the **↕** keys to cycle to **FinE** then press **OK**

Cycle to **Yes** then press **OK** to Save.  
Or  
Cycle to **no** and **OK** to cancel any changes

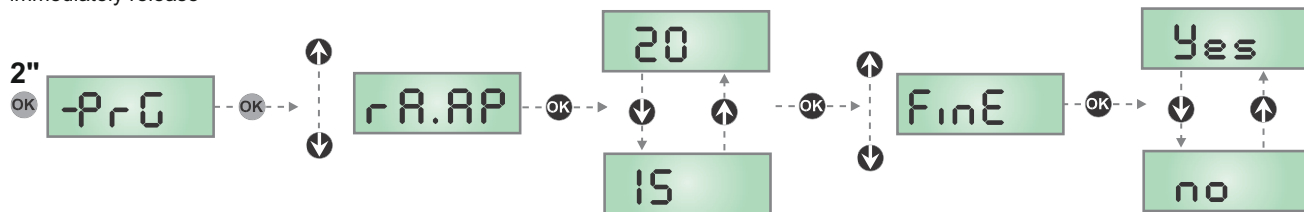

## Manually adjusting the slowdown distance for opening

Default is 15

The distance in % can be adjusted based on the cycle duration in which the slowdown will begin. For example if set to 15 then it will be the last 15% of the cycle. The adjustment is from 0% to 100%

Press and hold the **OK** button for about two seconds til the screen displays **PrG** then immediately release

Use the UP/Down keys to cycle to **rA.Ch** then press **OK**

Use the **↕** keys to cycle and adjust the position of the slowdown by %

Use the **↕** keys to cycle to **FinE** then press **OK**

Cycle to **Yes** then press **OK** to Save.  
Or  
Cycle to **no** and **OK** to cancel any changes

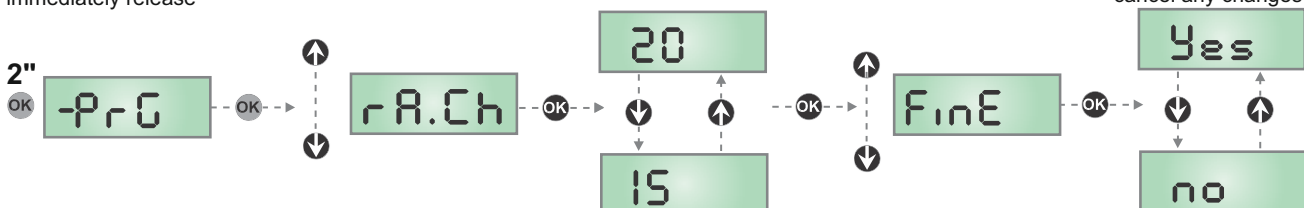

## Connecting Driveway or Garden Lights

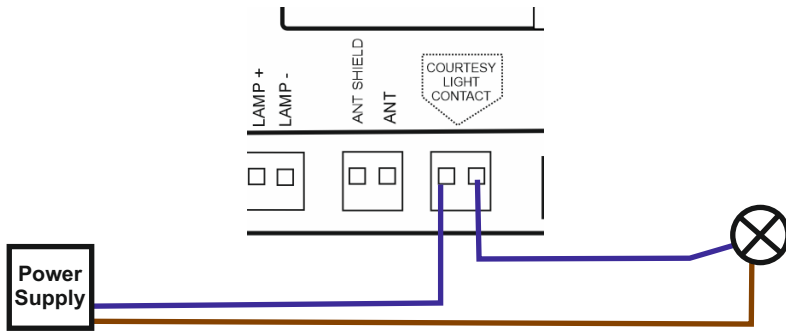

The internal relay will support up to a maximum of 230V AC (5A)

## Setting the Light output

Default is On for 1 minute

The light output can be set to OFF, On for the cycle duration or set to be on from 5 seconds to 20 minutes.

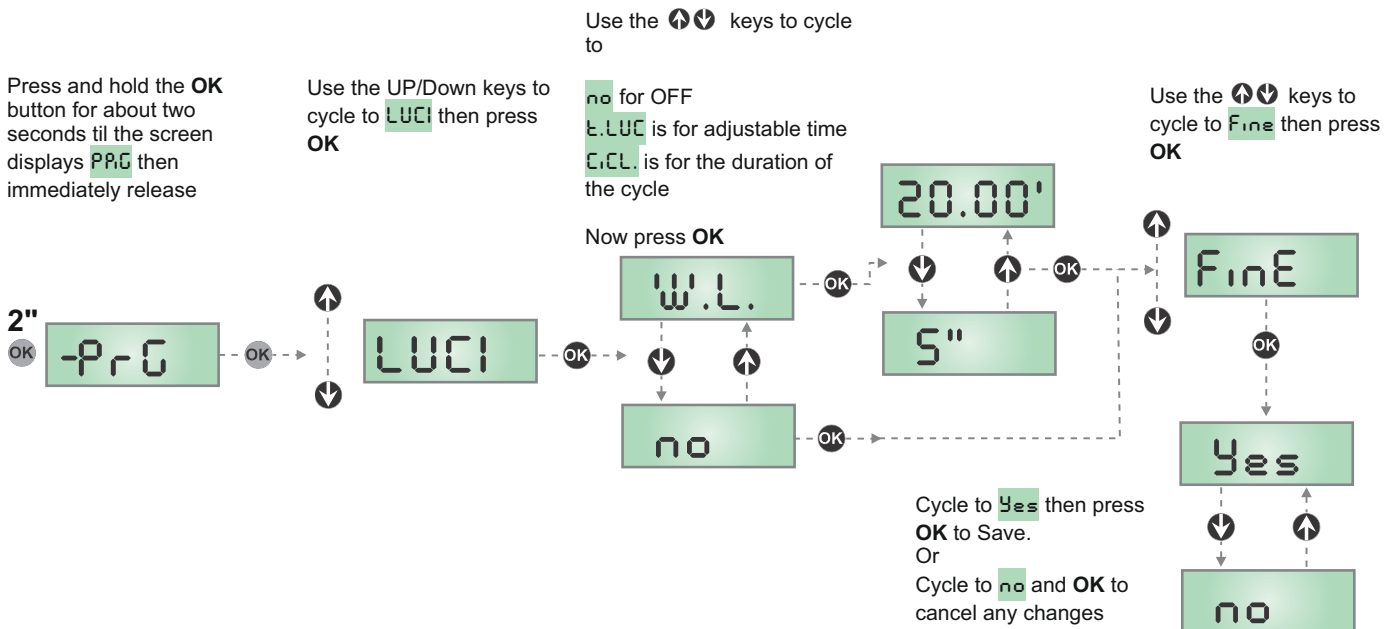

## Setting the Light output

Default is Momentary

The light output can be set to be toggled by button 4 on the remote in a timed state (5 second to 20 minutes), Momentary pulse or latching circuit.

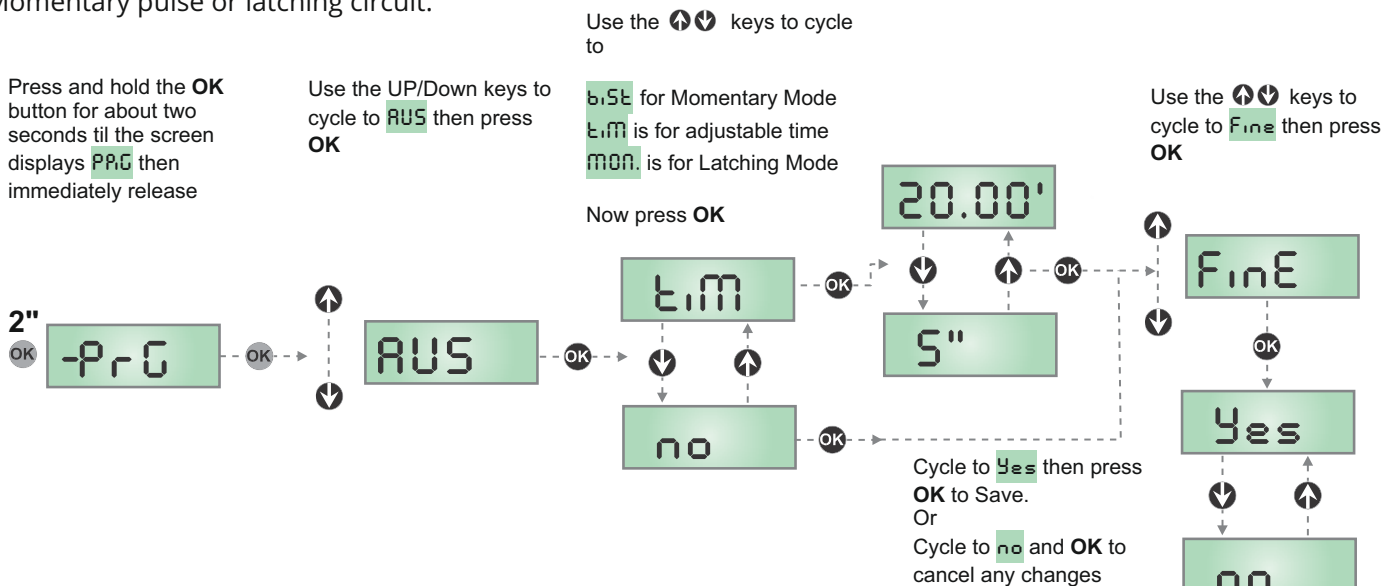

## Adjusting the Pedestrian opening distance

Default is 25%

The pedestrian gate operation can be adjusted to suit the installation requirements based on percentage of the full gate operations learned distance.

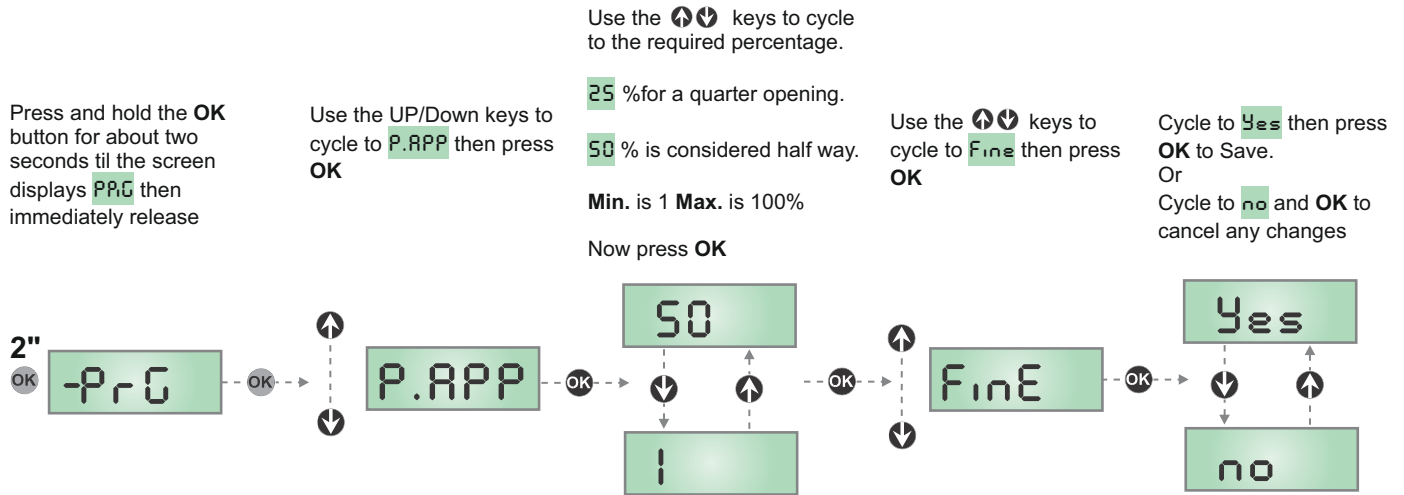

## Triggering Pedestrian Operation DURING pedestrian cycle

Default is Off

This logic setting is if the pedestrian function was triggered whilst already moving in a pedestrian operation.  
**PAUS** is the default and will simply stop the gate, it will stay in this position until the user triggers the operation again.  
**CHIU** the gate will immediately stop and start to close.  
**no** setting will ignore the command.

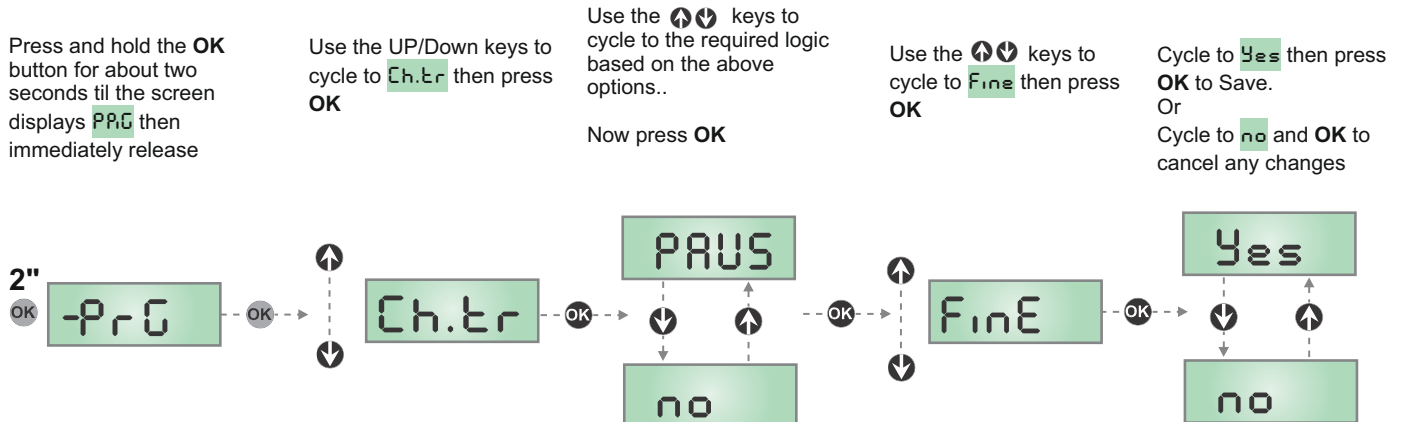

**Note:** A full gate operation command will always take priority and cause the gate to complete a full gate operation regardless of the above setting. A pedestrian gate operation command however will not take priority over a full gate operation command and will be ignored.



## Full Gate Operation Trigger during Closing

Default is Stop

Adjust the response of the system when full gate operation command is triggered whilst closing

1. **Stop** When the command is triggered the gate will stop
2. **APER** When the command is triggered the gate will stop and revert back to the close.

Press and hold the **OK** button for about two seconds til the screen displays **PrG** then immediately release

Use the UP/Down keys to cycle to **St.Ch** then press **OK**

Use the  $\uparrow/\downarrow$  keys to cycle to  
Select the logic based on the above.

Use the  $\uparrow/\downarrow$  keys to cycle to **FinE** then press **OK**

Cycle to **Yes** then press **OK** to Save.  
Or  
Cycle to **no** and **OK** to cancel any changes

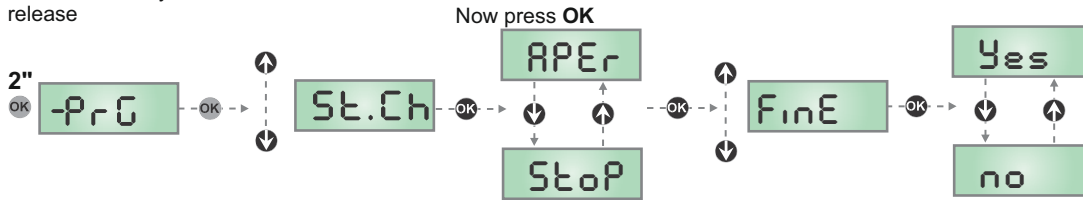

## Full Gate Operation Trigger during Opening

Default is Pause

Adjust the response of the system when full gate operation command is triggered whilst opening

1. **PAUS** When the command is triggered the gate will pause.
2. **ChiU** When the command is triggered the gate will stop and revert back to the close.
3. **no** When the command is triggered the gate will continue and ignore the command.

Press and hold the **OK** button for about two seconds til the screen displays **PrG** then immediately release

Use the UP/Down keys to cycle to **St.AP** then press **OK**

Use the  $\uparrow/\downarrow$  keys to cycle to  
Select the logic based on the above.

Use the  $\uparrow/\downarrow$  keys to cycle to **FinE** then press **OK**

Cycle to **Yes** then press **OK** to Save.  
Or  
Cycle to **no** and **OK** to cancel any changes

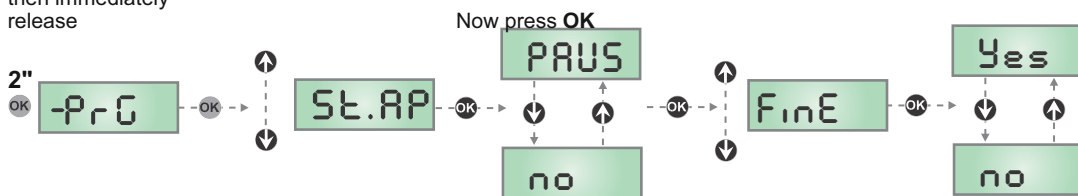

## Full Gate Operation Trigger during Pause

Default is Closing

Adjust the response of the system when full gate operation command is triggered whilst opening

1. **PAUS** When the command is triggered the automatic close timer will restart.
2. **ChiU** When the command is triggered the gate will close.
3. **no** When the command is triggered the system will ignore.

Press and hold the **OK** button for about two seconds til the screen displays **PrG** then immediately release

Use the UP/Down keys to cycle to **St.PA** then press **OK**

Use the  $\uparrow/\downarrow$  keys to cycle to  
Select the logic based on the above.

Use the  $\uparrow/\downarrow$  keys to cycle to **FinE** then press **OK**

Cycle to **Yes** then press **OK** to Save.  
Or  
Cycle to **no** and **OK** to cancel any changes

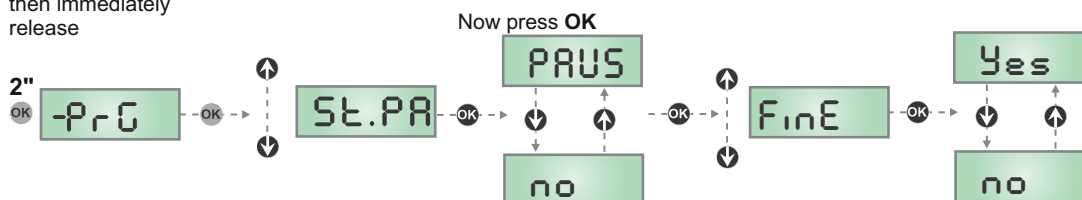

## Adjusting the STOP input (J3)

Default is Off

By default the stop input is ignored (no), if the stop input is activated it can be set from two different logics.

1. **ProS** When the input is triggered the gate will stop, when triggering start the gate will continue operating in the SAME direction
2. **invE** When the input is triggered the gate will stop, when triggering start the gate will continue operating in the OPPOSITE direction

Press and hold the **OK** button for about two seconds til the screen displays **PrG** then immediately release

Use the UP/Down keys to cycle to **StOP** then press **OK**

Use the  $\uparrow/\downarrow$  keys to cycle to  
Select the logic based on the above.

Use the  $\uparrow/\downarrow$  keys to cycle to **FinE** then press **OK**

Cycle to **Yes** then press **OK** to Save.  
Or  
Cycle to **no** and **OK** to cancel any changes

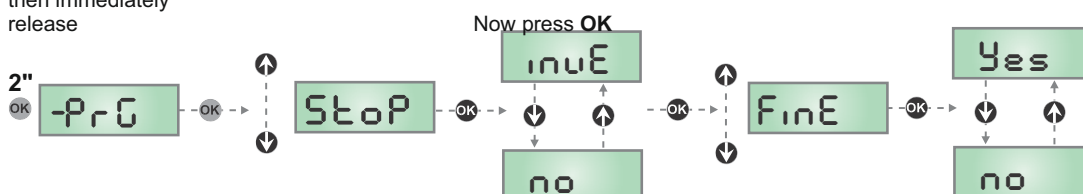

## Enable/Disable Safety Edge 1

Default is OFF

The EDGE 1 input is used for fixed safety edges. By default it is set to no which is OFF. It has two options for Logic:

1. APCh Sets the edge to be active in OPENING and CLOSING cycles
2. AP sets the input to be active in the OPENING cycle only.

Press and hold the **OK** button for about two seconds til the screen displays **PrG** then immediately release

Use the UP/Down keys to cycle to **CoS1** then press **OK**

Use the  $\uparrow/\downarrow$  keys to adjust the logic then press **OK**

Use the  $\uparrow/\downarrow$  keys to cycle to **FinE** then press **OK**

Cycle to **Yes** then press **OK** to Save.  
Or  
Cycle to **no** and **OK** to cancel any changes

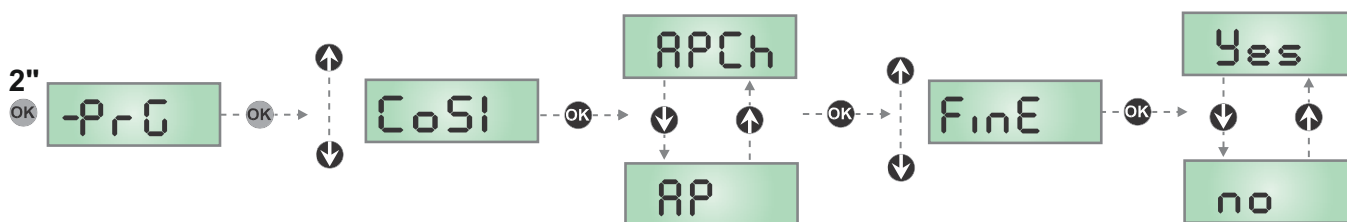

## Enable/Disable Safety Edge 2

Default is OFF

The EDGE 2 input is used for optical safety edges. By default it is set to no which is OFF. It has two options for Logic:

1. APCh Sets the edge to be active in OPENING and CLOSING cycles
2. Ch sets the input to be active in the CLOSING cycle only.

Press and hold the **OK** button for about two seconds til the screen displays **PrG** then immediately release

Use the UP/Down keys to cycle to **CoS2** then press **OK**

Use the  $\uparrow/\downarrow$  keys to adjust the logic then press **OK**

Use the  $\uparrow/\downarrow$  keys to cycle to **FinE** then press **OK**

Cycle to **Yes** then press **OK** to Save.  
Or  
Cycle to **no** and **OK** to cancel any changes

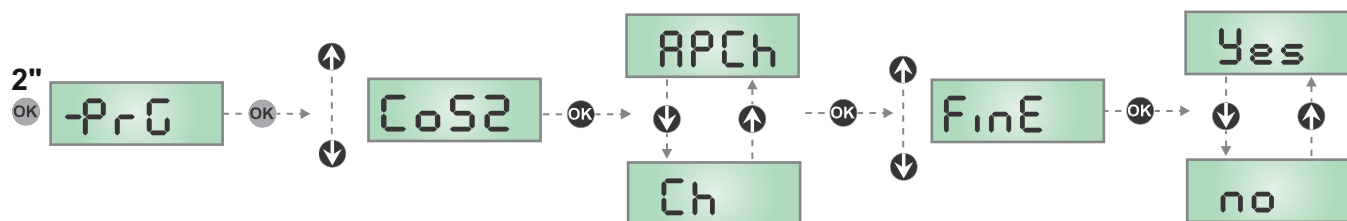

## Safety Edge Check Before Motion



"Check before motion" for Safety Edge

Default is OFF

Press and hold the **OK** button for about two seconds til the screen displays **PrG** then immediately release

Use the UP/Down keys to cycle to **Co.tE** then press **OK**

Use the  $\uparrow/\downarrow$  keys to adjust the logic then press **OK**

Use the  $\uparrow/\downarrow$  keys to cycle to **FinE** then press **OK**

Cycle to **Yes** then press **OK** to Save.  
Or  
Cycle to **no** and **OK** to cancel any changes

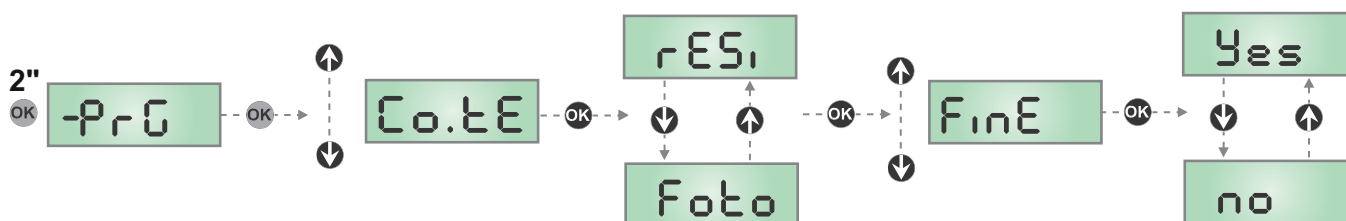

**Note:** Enabling the test mode prior to operation is a necessity if the system is set to power conservation mode EnSA

## System overrides and Manual tests

### Manually moving the gate using logic control

This method is used for diagnostics and testing of the gate motor itself. It will bypass all safety edges, photocell, limits and encoder.

Press and hold the **OK** button for about two seconds til the screen displays **PPG** then immediately release

Use the UP/Down keys to cycle to **MAN** then press **OK**

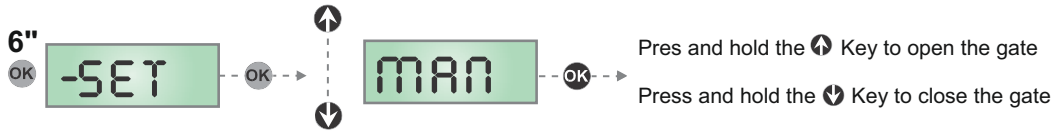

### Manually moving the gate using dead man mode

This method is used for emergencies requiring the gate to be immediately be moved towards the open position. This will function the motor itself and bypasses all safety devices such as edge sensors and photocells.

To activate the START input must be triggered three consecutive times by ONE second Presses with a pause in between each press of ONE second. Once more the button will be held down for the fourth press indicating an operator is present. Whilst the button is held the gate will operate towards the open position.

This mode is automatically exited after 10 seconds of inactivity

If the system in the **5LR** menu is set to **5LRn** then the operator will open/close based on current/previous position.

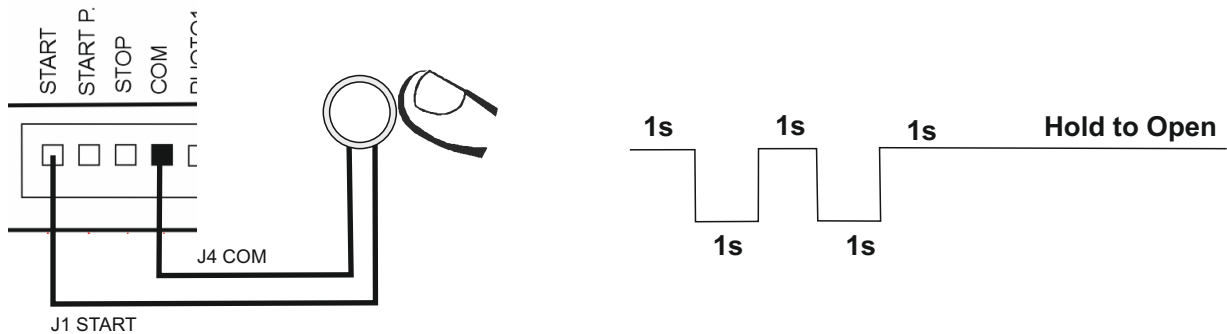

### Reset to Factory Default

This will set all parameters to default, any changes made to the settings will be lost however remote's and other wireless equipment will remian.

Press and hold the **OK** button for about two seconds til the screen displays **dEF** then immediately release

Use the UP/Down keys to cycle to **dEF** then press **OK**

Use the **Up/Down** keys to adjust the logic then press **OK**

System will return to standby

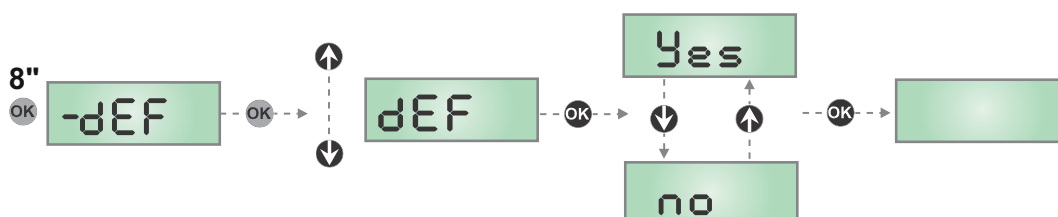

## Setting the service interval counter

A Counter can be set to indicate when a service is required, the service requirement will be indicated by an additional five seconds of pre-blinking time of the connected lamp prior to the opening cycle.

The counter will be reset once the cycle counter is reset to the required quantity of cycles, if the counter is set to zero then the counter will be disabled. Each open and close is considered ONE cycle.

Press and hold the **OK** button for about four seconds til the screen displays **Cnt** then immediately release

Use the UP/Down keys to cycle to **Set** then press **OK**

Pressing **▲** will go up in thousands

Pressing **OK** returns to standby.

Pressing **▼** will go down in hundreds

**if set to 0 the counter will be disabled**

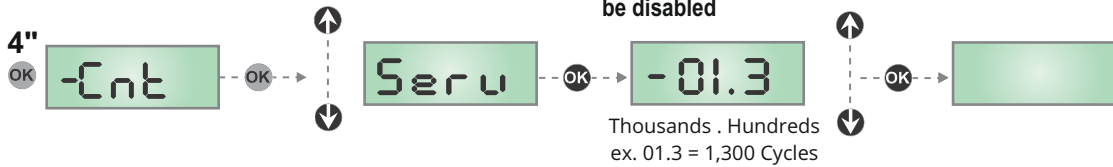

## Viewing the total cycle count

The total cycle count cannot be reset, this is reading the total open and closes and considering them together as one cycle.

Press and hold the **OK** button for about four seconds til the screen displays **Cnt** then immediately release

Use the UP/Down keys to cycle to **tot** then press **OK**

First screen will show from 001. thousand up to 999. thousand.

Pressing **OK** returns to standby.

Pressing **▼** will show the hundreds of cycles from .001 to .999 cycles .

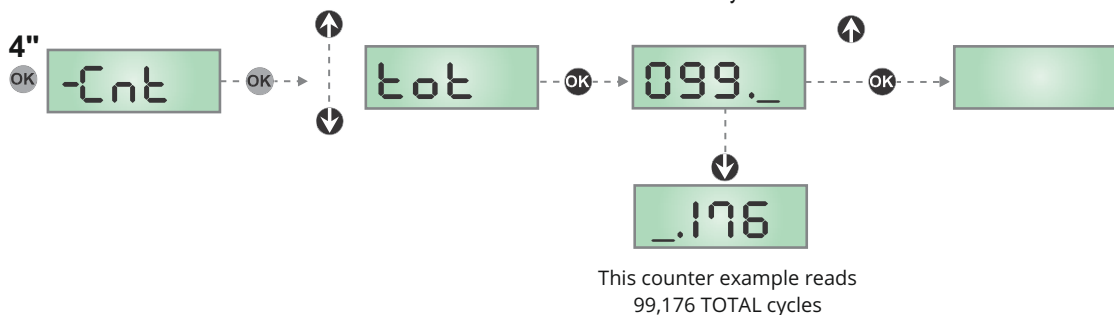

## Setting a Bi Parting Gate Installation (TWO motors, one set of accessories, operating together)

To set a Master and Slave system TWO syncro modules are required to be connected into the interface port of each motor unit. The syncro modules are connected to one another using a TWISTED pair, the connection is non-polarised.

Each motor unit must be configured for its **own** travel direction and travel time settings independently including all other motor related settings. This should be performed prior to connecting the Syncro Module or performing the setting steps below.

All the accessories settings of the systems will be set only on the MASTER motor unit, these will be relayed to the slave automatically.

If pedestrian function is used it will only partially operate the MASTER gate based on its setting.

Press and hold the **OK** button for about two seconds til the screen displays **PrG** then immediately release

Use the UP/Down keys to cycle to **Ad1**, then press **OK**

Use the  $\uparrow/\downarrow$  keys to adjust the logic then press **OK**

If the module is connected **SYnC** will automatically be displayed, press **OK**

Choose whether the unit is a Master **MAS** or a Slave **SLA** then press **OK**.

**Repeat for the other motor**

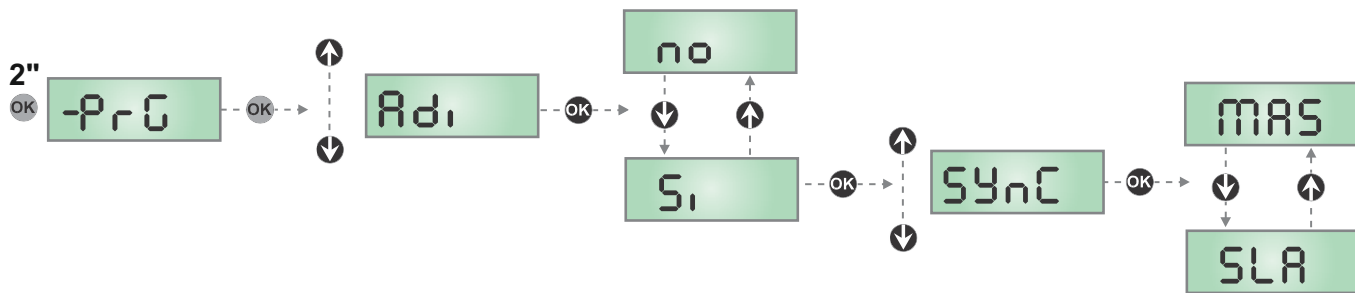

## Installation Layout

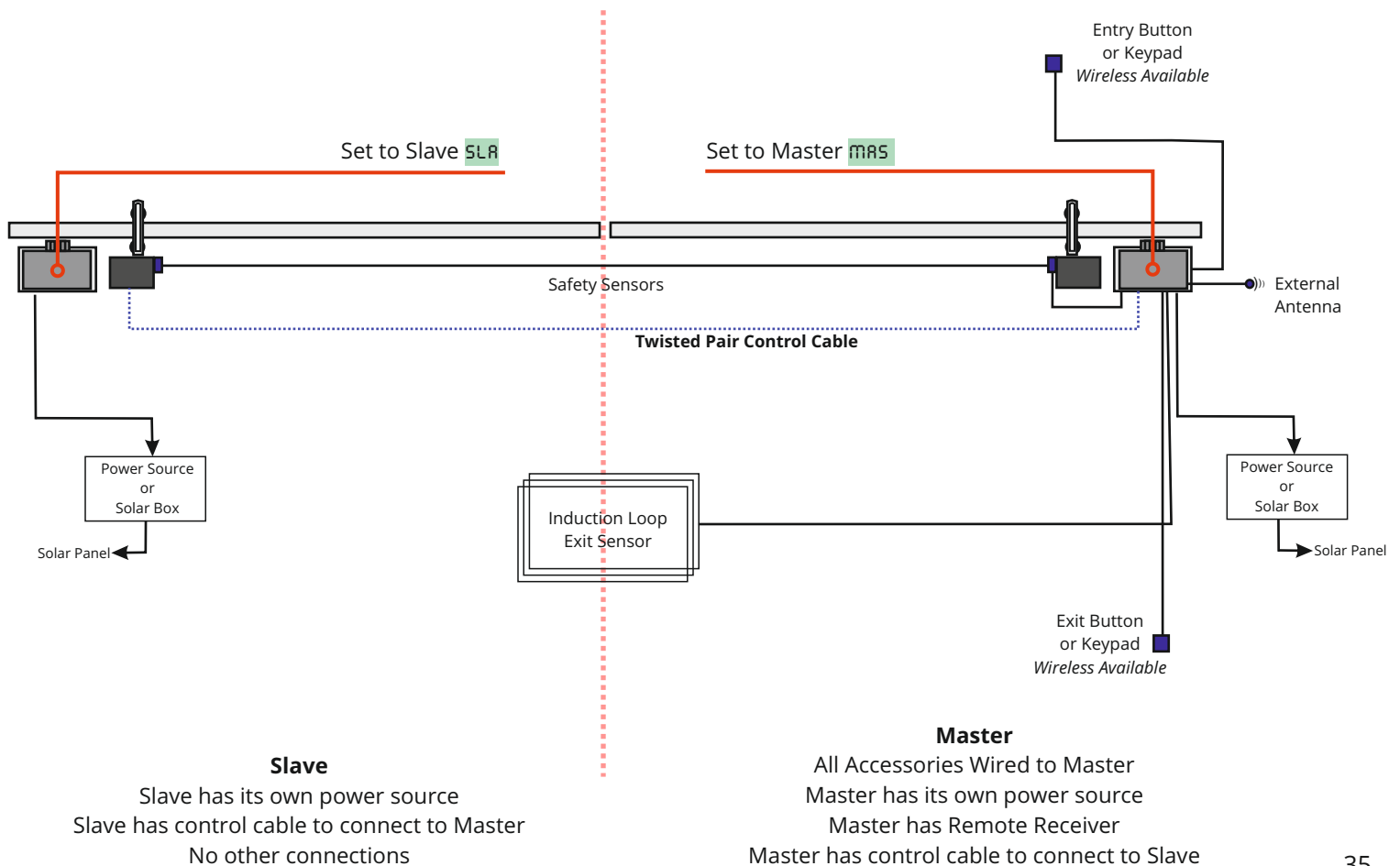

## Troubleshooting

Overload LED On	Unplug the accessories power connector E1-E5 and disconnect all accessories. Fault find the faulty accessory power
Pre-Blinking longer than originally set	Indicates that the set cycle counter has lapsed and motor requires a service by the installer.
Slow movement of gate whilst closing then returns to normal	Motor encoder is out of alignment, power failure could occur whilst the gate was open.

Err1	Data could not be stored error. Fault with control board.
Err2	Motor not connected or motor driver issue on control board.
Err3	<ul style="list-style-type: none"> <li>- Obstacle in sensor path</li> <li>- No sensor connected but sensor logic is enabled</li> </ul>
Err4	<ul style="list-style-type: none"> <li>- Command sent to open but motor is on clutch</li> <li>- Whilst in self learning: Magnets incorrect orientation (Sx and Dx)</li> <li>- No magnet detected during operation</li> <li>- Limit reader problem</li> </ul>
Err5	Safety Edge test configured incorrectly
Err7	<p>When an operation command is given but does not open (or partially opens) and displays error it could mean one of the following:</p> <ul style="list-style-type: none"> <li>- Motor/gate is mechanically locked</li> <li>- Learning of travel is not performed correctly</li> <li>-Encoder fault or no connection</li> </ul>
Err8	<ul style="list-style-type: none"> <li>- A setting of Logic is not compatible with another logic parameter ex. ADI is enabled but not interface module connected</li> <li>- If the error occurs during the self learning the Strt parameter must be set to Stan and Adi to no</li> </ul>
Err9	Settings have been locked out by programmer module
Err10	Error 10 indicates Interface module is not connected correctly or is not connecting to the controller

## Compatible Equipment

The equipment listed below does not affect the warranty of the control panel and have been tested and approved for use. Limited warranty is applied to the control panel when used with third party equipment.

<b>Sensors</b>	<b>Receivers</b>	<b>Remotes</b>	<b>Keypads</b>	<b>Solar Equipment</b>
- APC-PE2000	- APC-Connect 4	- APC-RC4S	- APC-KP1-C	- APC Sun Power
- APC-RR-11	- APC-RX4	- APC-RC4SV	- APC-KP2W	- APC-SP24-20W
- APC-LD1-24V	- APC-WF-CH1	- APC-RC450S	- APC-WF-KP	- APC-SP24-40W
				- APC-SP24-60W
<b>Courtesy Light</b>	<b>Push Buttons</b>	<b>External Transformers</b>		
- APC-ULA	- APC-PBS (K/KW)	- PS-24-10		
	- APC-PBD (K/KW)			

## Warranty Terms

### APC WARRANTY

APC Automation Systems warrants the original purchasers or the APC gate(s) opening system for a period of twelve months from the date of purchase (not installation), the product shall be free of defects in materials and workmanship under normal use.

During the warranty period, APC shall, as its option, repair or replace any defective product upon return of the product to its factory, at no charge for labour and materials.

Any replacement and/or repaired parts are warranted for the remainder of the original warranty, The original owner must promptly notify APC in writing that there is defect in material or workmanship, such written notice must be received in all events prior to expiration of the warranty.

### International Warranty

APC shall not be responsible for any freight fees, taxes or customs fees.

### Warranty Procedure

To obtain service under this warranty, AND AFTER CONTACTING APC, please return the item(s) in question to the point of purchase.

All authorized distributors and dealers have a warranty program, anyone returning goods to APC must first obtain an authorization number.

APC will not accept any shipment for which prior authorization has not been used.

### Conditions to Void Warranty

This warranty applies only to defects in repairs and workmanship relating to normal use. It does not cover:

- Damage incurred in shipping or handling
- Damage caused by disaster such as fire, flood, wind, earthquake or lightning
- Damage due to causes beyond the control of APC such as excessive voltage, mechanical shock or water damage
- Damage caused by unauthorized attachment, alterations, modifications, or foreign objects.
- Damage caused by peripherals (unless such peripherals were supplied by APC)
- Defects caused by failure to provide a suitable installation environment for the products
- Damage caused by usage of the products for purpose other than those for which it was designed.
- Damage from improper maintenance
- Damage arising out of any other abuse, mishandling, and improper application of the products.

Under no circumstances shall APC be liable for any special, incidental, or consequential damages based upon breach of warranty, breach of contract, negligence, strict liability, or any other legal theory. Such damages include, loss of profits, loss of the product or any associated equipment, cost of capital, cost of substitute or replacement equipment, facilities or services, down time, purchaser's time, the claims of third parties, including customers, and injury to property.

### Disclaimer of Warranties

This warranty contains the entire warranty and shall be in lieu of any and all other warranties, whether expressed or implied (including all implied warranties of merchantability or fitness for a particular purpose). And of all other obligations or purporting to act on its behalf to modify or to change this warranty, nor to assume for it any other warranty or liability concerning this product.

### Out of Warranty Repairs

APC will at its option repair or replace out-of-warranty products which are returned to its factory according to the following conditions.

Anyone returning goods to APC must first obtain an authorization number.

APC will not accept any shipment whatsoever for which prior authorization has not been obtained.

Products which APC determines to be repairable will be repaired and returned. A set fee which APC has been predetermined and which may be revised from time to time will be charged for each unit repaired. Products which APC determines not repairable will be replaced by the nearest equivalent product available at that time. The current market price for the replacement product will be charged for each replacement unit.